

Splash and Dash

GROOMERIE & BOUTIQUE

- CONSTRUCTION BOOKLET -

Version 2.1



Disclaimer

All plans and illustrations contained in this publication are the exclusive property of SD Franchise LLC, dba Splash and Dash Groomerie & Boutique and reproduction in whole or in part is strictly prohibited by law.

All information and construction plans contained within this document are provided AS IS. SD Franchise LLC, disclaims all other warranties, express or implied, including merchantability or fitness of purpose. Construction plans must be submitted to a local architect for approval. SD Franchise LLC is not liable for incidental, special, consequential, or indirect damages of any kind, including, but not limited to, loss of anticipated profits, business opportunity or other economic loss arising out of the use of services or any construction plans received from SD Franchise LLC, even if SD Franchise LLC has been advised of the possibility of such damage.

It is the franchisee's responsibility to ensure the accuracy, compliance with applicable statute(s) or regulation(s), and fitness of purpose of any plans or construction information received from SD Franchise LLC prior to the use thereof.

Information on Building Codes:

SD Franchise LLC, does not assume any knowledge of local, state or federal building codes. All plans MUST reviewed by a local professional architect or engineer before the start of construction or such services that are best handled by those familiar with your local building codes.

Plan Usage

1. All plans are protected by Federal Copyright Laws. Any use of the information contained herein beyond the one-time use authorized by SD Franchise LLC. of prints, or any duplication, publication, sale or distribution of any part of these plans without the prior written consent of SD Franchise LLC Designer represents a violation of Federal Laws subject to the prescribed penalties.

2. Any use of the plans, or modifications of the plans, by Franchisee, builders or others is done at their own risk. Franchisee should have the plans reviewed by a local professional architect or engineer before the start of construction. The information contained within the construction documents is intended to depict design and basic construction detailing. It is the builder's responsibility to provide standard construction details and practices which will result in a structurally sound and weatherproof finished product.

Plan Content

These Plans provide ideas and concepts and are not intended to be complete in all respects and details. Variations in standard sizes of window and door brands and types and use of different materials and thicknesses can change details. Varying local codes, ordinances, regulations, foundation requirements, and the layout of electrical, mechanical, and plumbing systems can also change details.

Responsibility of Builder/Contractor hired by Franchisee

1. It is the responsibility of the builder to assure that all work is in accordance with the latest edition of all applicable Nation, State, and Local Building Codes. It is the builder's responsibility to ensure that all work is conducted in accordance with the latest edition of all applicable Construction Standards.

2. It is the responsibility of the builder to ensure that all manufactured articles, material, and equipment are applied, installed, connected, erected, used, cleaned, adjusted, operated and conditioned as directed by the manufacturers. Builder shall follow all instruction to sustain and preserve all expressed or implied warranties and guarantees.

3. It is the responsibility of the builder to assure that all materials, equipment and components are new and of good quality.

4. It is the responsibility of the builder to check all dimension and details for overall accuracy appropriate to the local conditions and the final selection of materials such as masonry, floor joists, lumber, structural members, construction panels, roofing, etc., all of which can create variations in dimension and details. For example, if standard lumber joists are used in place of engineered floor joists, the floor-to-floor dimension would vary from the Plans and require revised stair dimension and framing.

Table of Contents

1 - Contractor's Tasks

Pg. 01

Store Front Floorplan	Pg. 02
Store Back Floorplan	Pg. 03
Retail Desk	Pg. 04
Work Area - Drying Stations	Pg. 06

2 - Handyman's Tasks

Pg. 07

Retail Wall 3	Pg. 08
Work Area - Grooming Stations	Pg. 09
Uline Racks	Pg. 10
Tall Bookcase Assembly	Pg. 11
Spa Assembly and Setup	Pg. 12
Collar Ladder Assembly	Pg. 13
Slatwall Panels	Pg. 14
Slatwall Placement	Pg. 15
Grooming Area Extras	Pg. 16

3 - Electrician's Tasks

Pg. 17

Store Front Electrical Plan + Details	Pg. 18
Store Back Electrical Plan + Details	Pg. 19
Ceiling Grid	Pg. 20

4 - Plumber's Tasks

Pg. 21

Store Back Plumbing Plan	Pg. 22
Work Area Tub Stations + Details	Pg. 23

5 - Painter's Tasks

Pg. 24

Wall Paint Colors	Pg. 25
-------------------	--------

6 - Owner's Tasks

Pg. 26

Store Front Ikea Furniture Placement	Pg. 27
Store Front Signage Placement	Pg. 28
Store Back Floorplan	Pg. 29
Splash and Dash Requirements	Pg. 30
Retail Desk PC Setup	Pg. 31

DISCLAIMER:

ALL DIMENSIONS ARE ESTIMATES PROVIDED BY THE CORPORATE OFFICE. THESE ARE GENERAL ESTIMATIONS BASED ON THE SQUARE FOOTAGE PROVIDED BY THE RETAIL SPACE OWNER. DESIGNS MY BE SUBJECT TO CHANGE BY ARCHITECT.

SECTION ONE:

All Tasks in this section should be
completed by:

The Contractor

Contractor - Store Front Floorplan

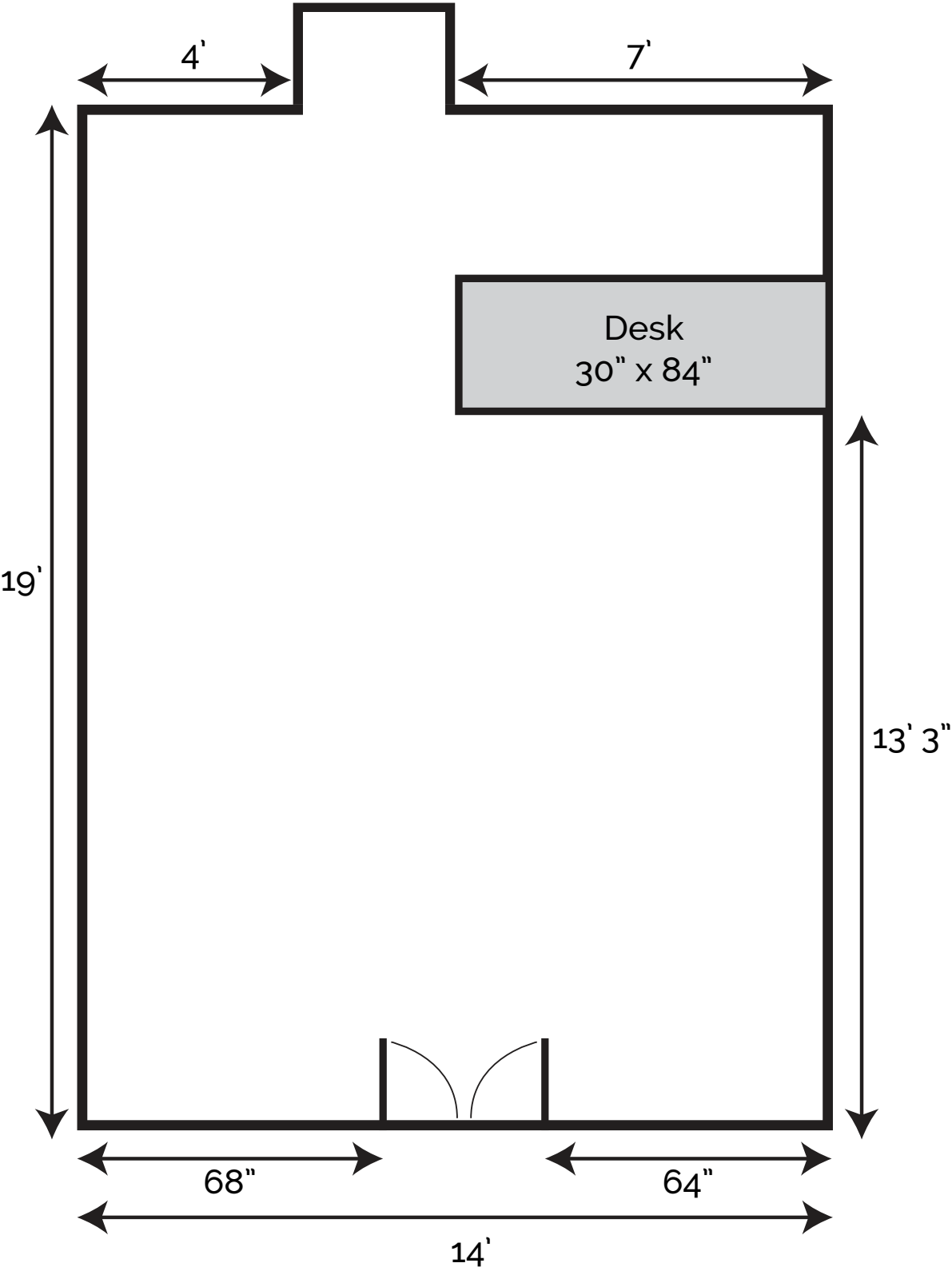

ATTENTION:

No Contractor changes to be made to back of the shop.
Retail changes only.

Contractor - Retail Desk Construction

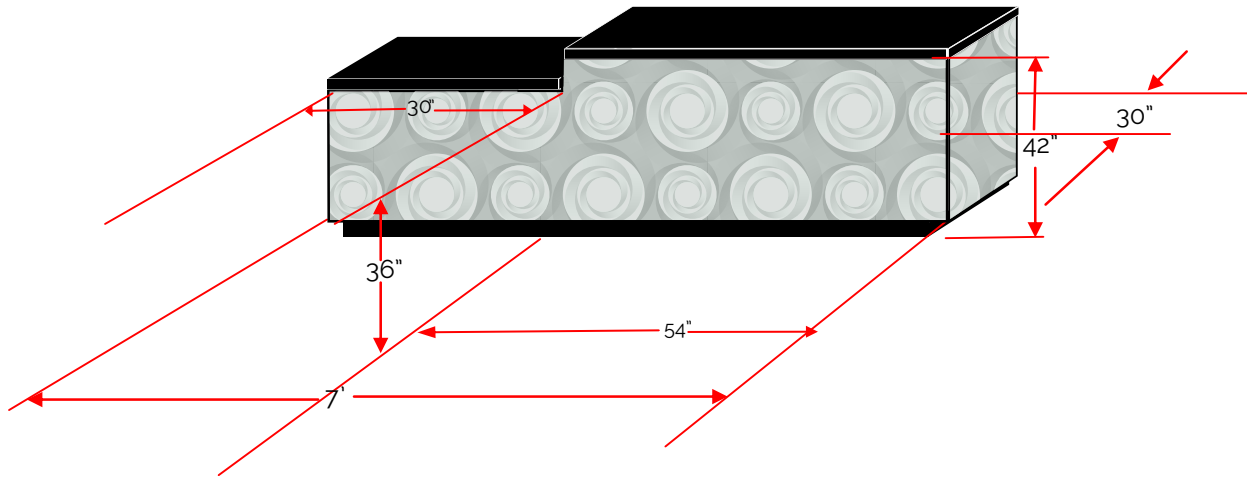

Counter top

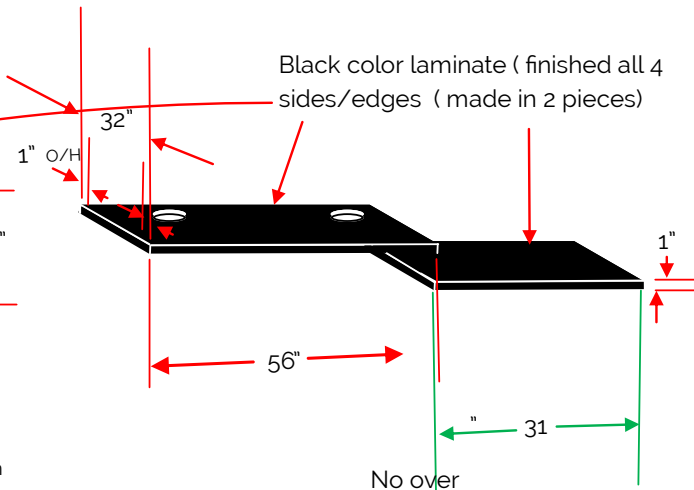
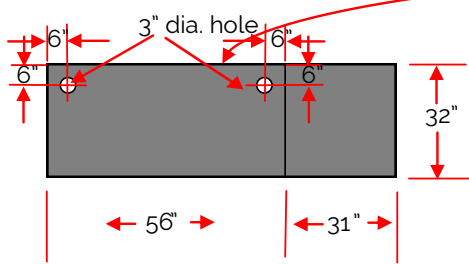

Base

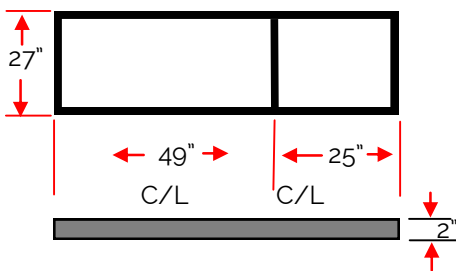

Center

Create with 2x4 frame and drywall (sheetrock) exterior surface. Primed white

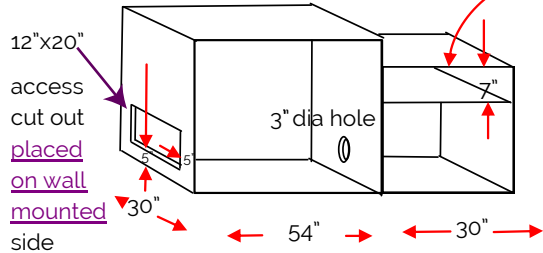

Cash drawer w/lock

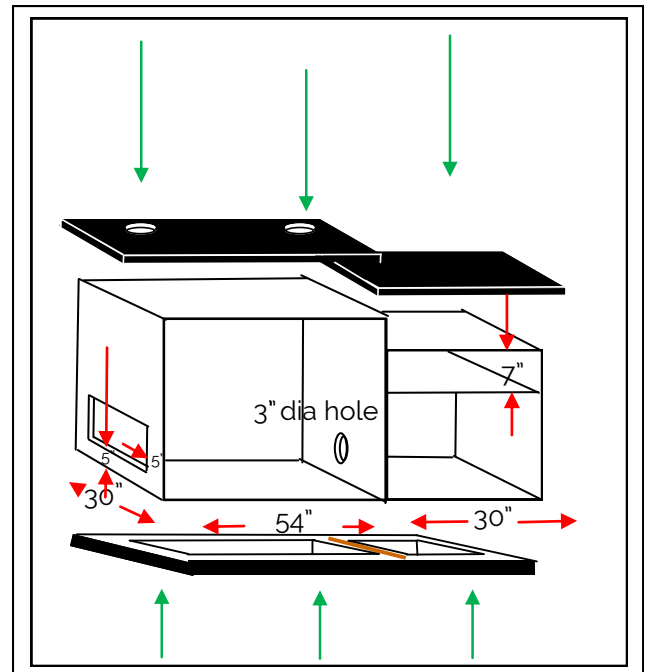

Contractor - Retail ADA Desk Interior

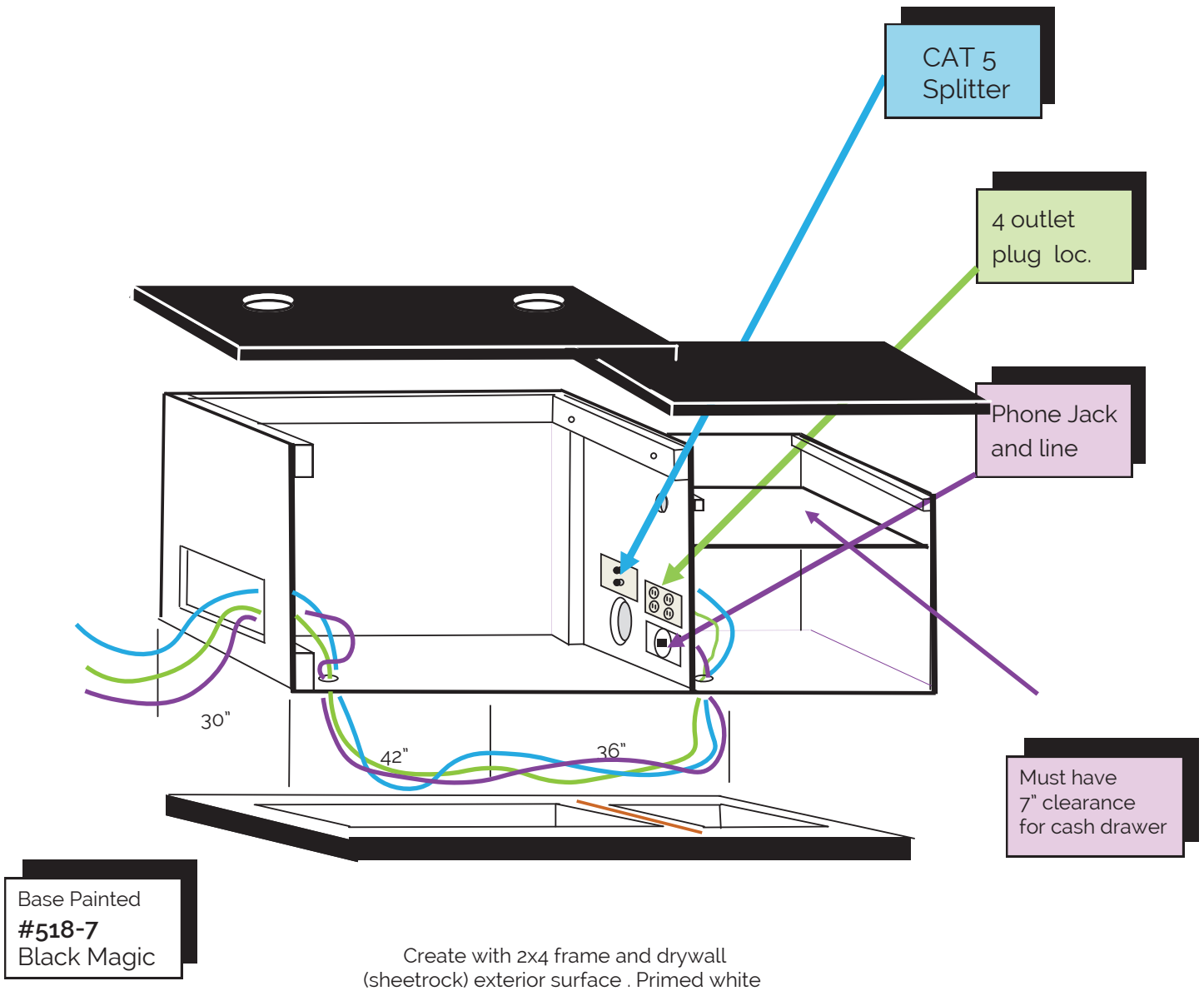

Contractor - Work Area: Drying Stations

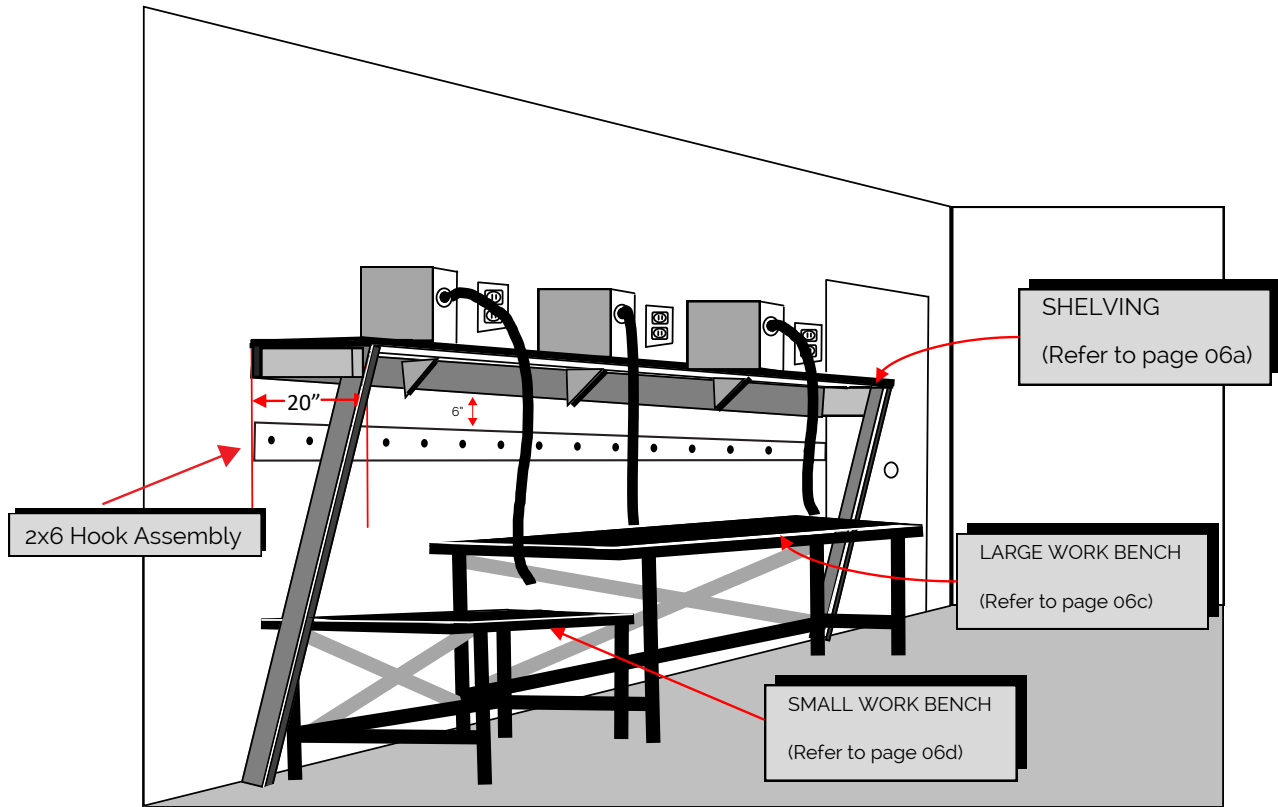

Drying Station

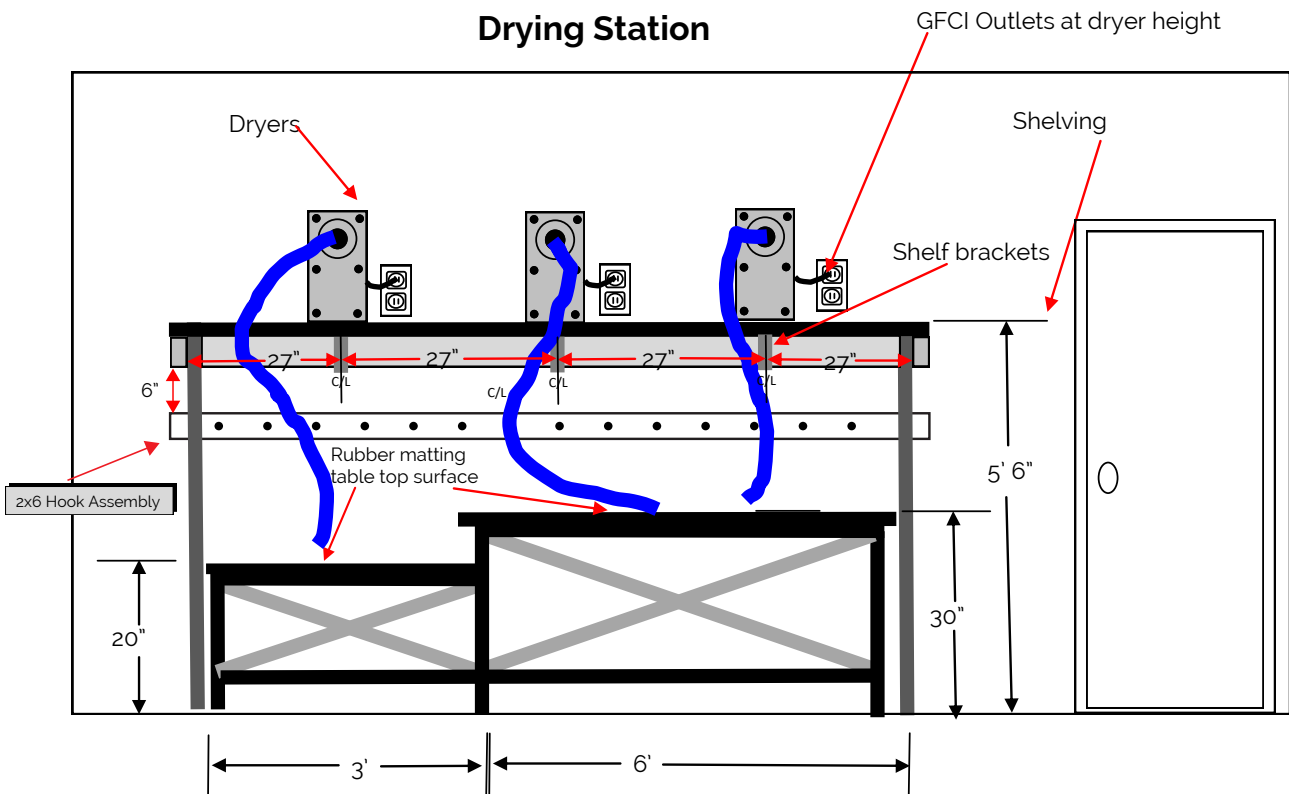

Contractor - Dryer Station Shelf/Bench Placement

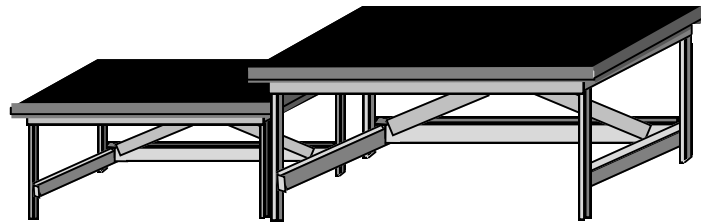

Wire rack Shelf
- Wired Closet Shelving from Lowe's or Home Depot

Shelving Brackets

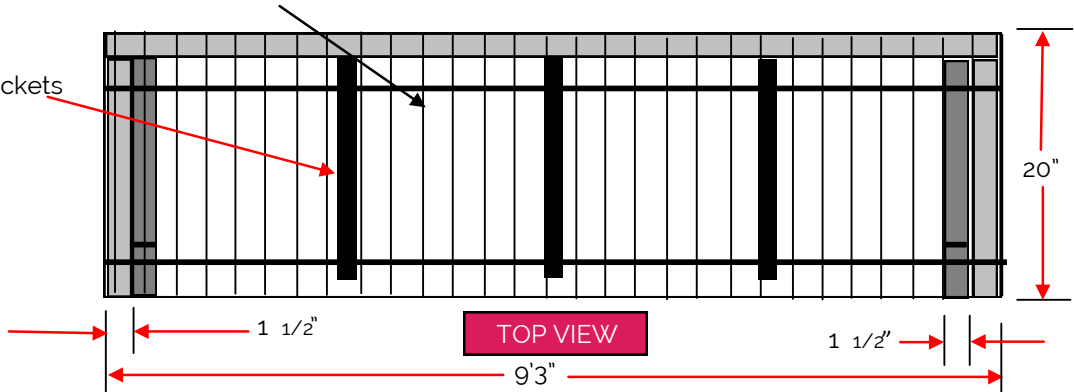

Drying Table hook assembly-
Mock up the 2x6 by placing it in the shelf mounts and marking where mounts line up on the 2x6.
Mark 2 screw hook locations in between each mount.
Drill all of your holes on the 2x6 before you hang so you can secure through pilot holes
After you drill, place the 2x6 in the mounts and mark on steel mounts through the pilot holes
Use 3" steel screws so you can reach through the 2x6, shelf mounts, and stud. Secure with a washer

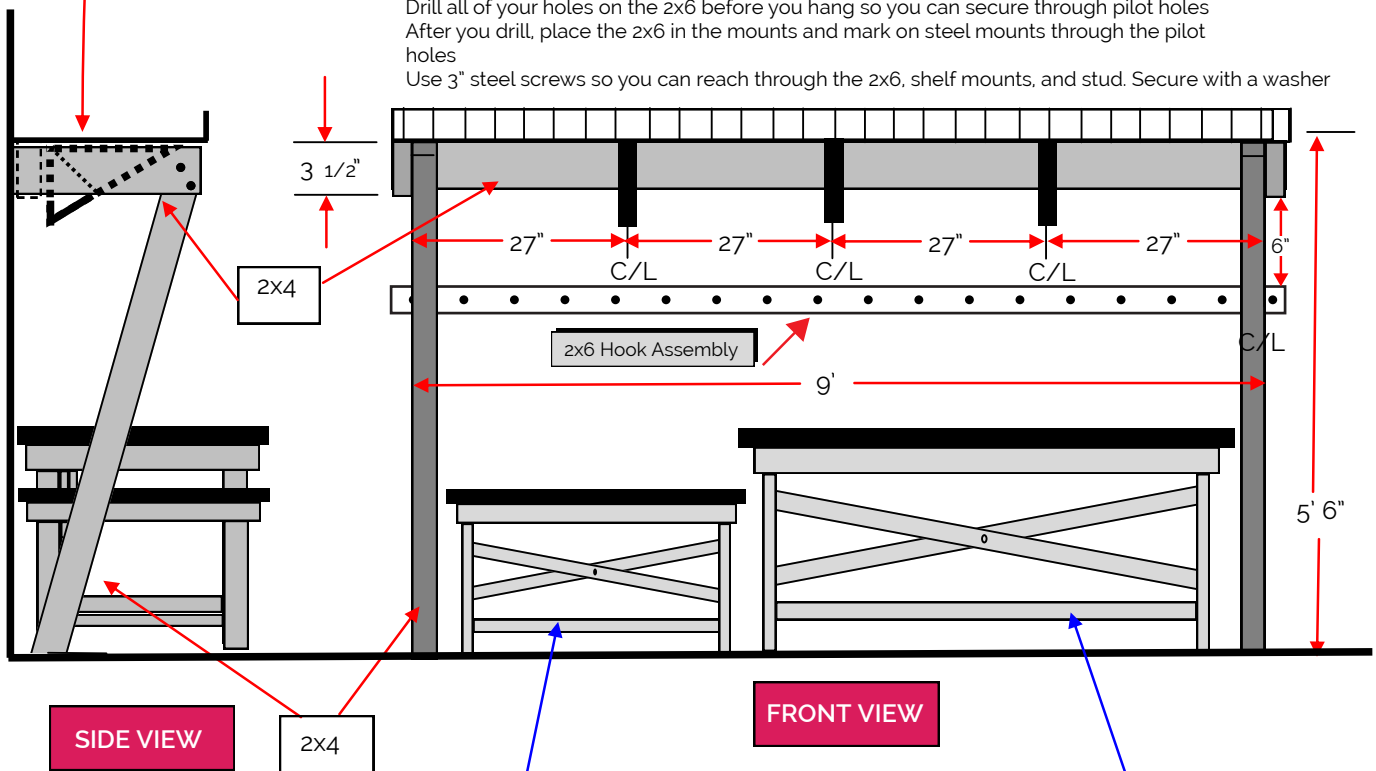

SMALL WORK BENCH

LARGE WORK BENCH

Contractor - Drying Table Hook Assembly

- Mock up the 2x6 by placing it in the shelf mounts and marking where mounts line up on the 2x6.
- Mark 2 screw hook locations in between each mount.
- Drill all of your holes on the 2x6 before you hang so you can secure through pilot holes
- After you drill, place the 2x6 in the mounts and mark on steel mounts through the pilot holes
- Use 3" steel screws so you can reach through the 2x6, shelf mounts, and stud. Secure with a washer







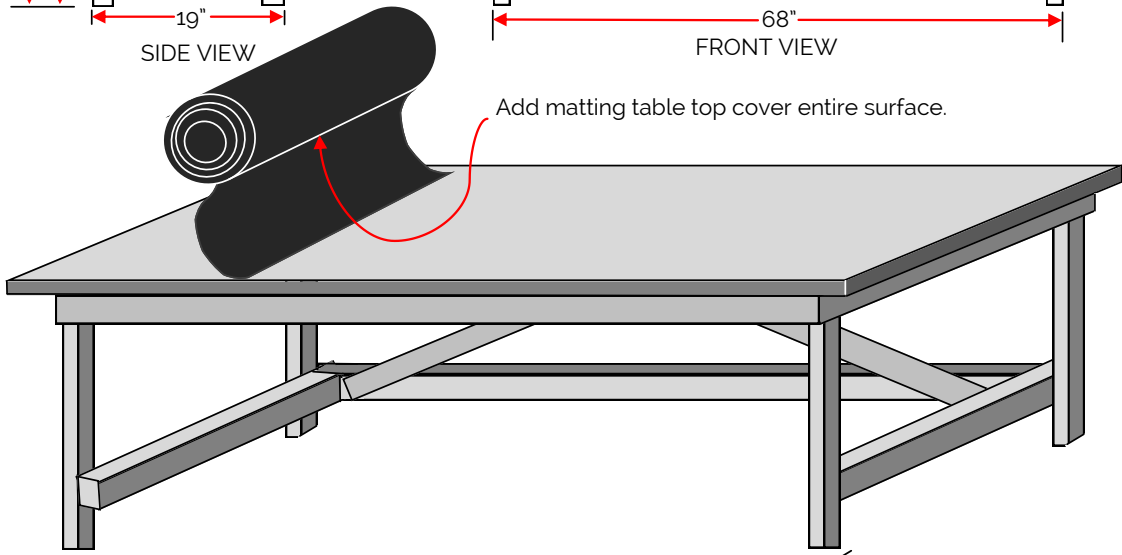
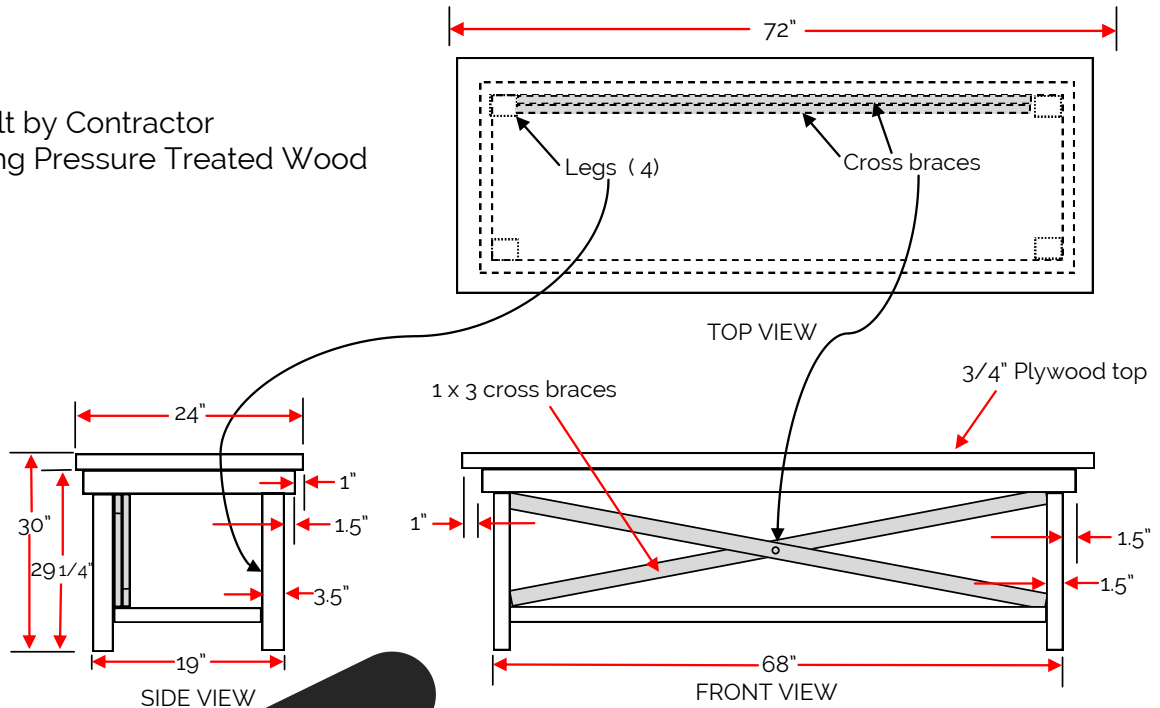

Contractor - Drying Station: Large Work Bench

*Built by Contractor using Pressure Treated Wood



All Pressure Treated Lumber

- KEY:
-  = Plywood Table top
 -  = 2x4's
 -  = 1 x 3 boards
 -  = 2 x 6 Hook Assembly
 -  ← Assmbl' 1x3's
 -  ← Assmbl' 2x4's
 -  ← Assmbl' top

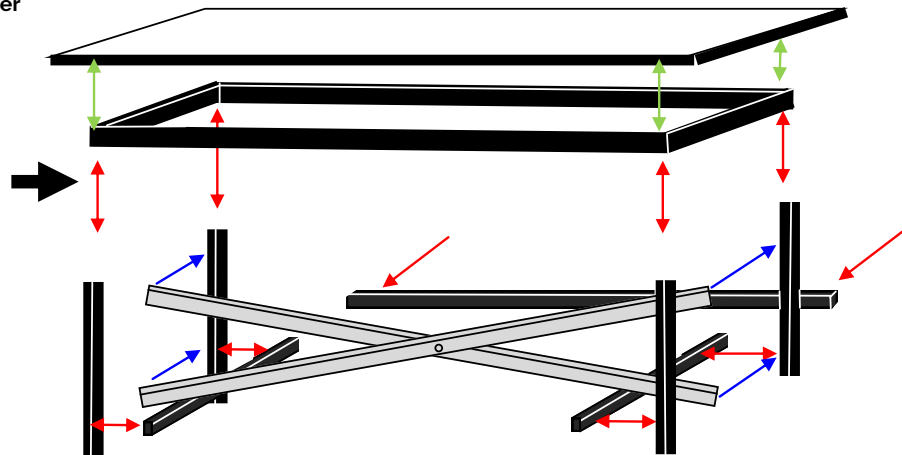

Contractor - Drying Station: Small Work Bench

*Built by Contractor
using Pressure Treated Wood

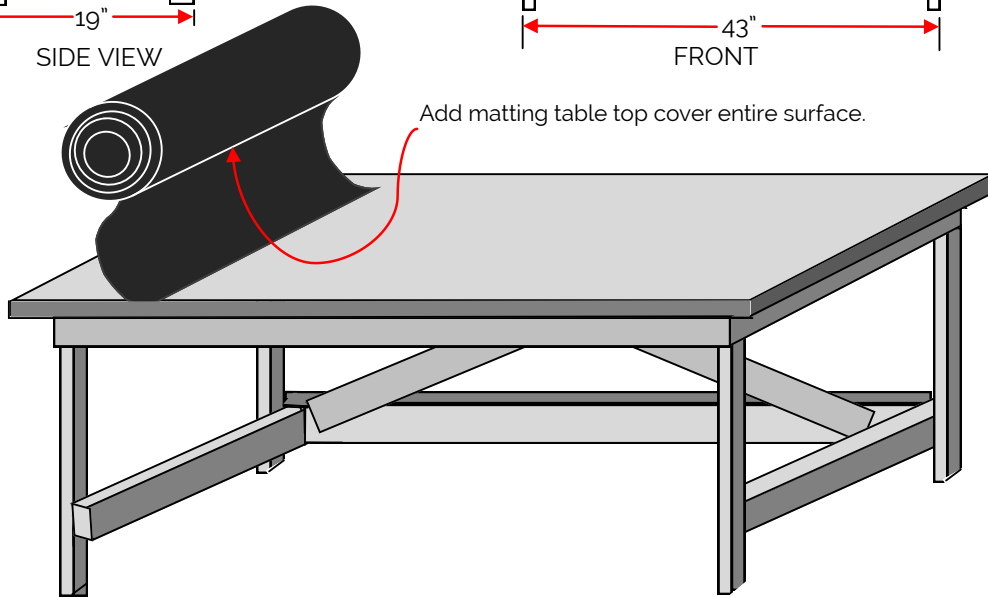
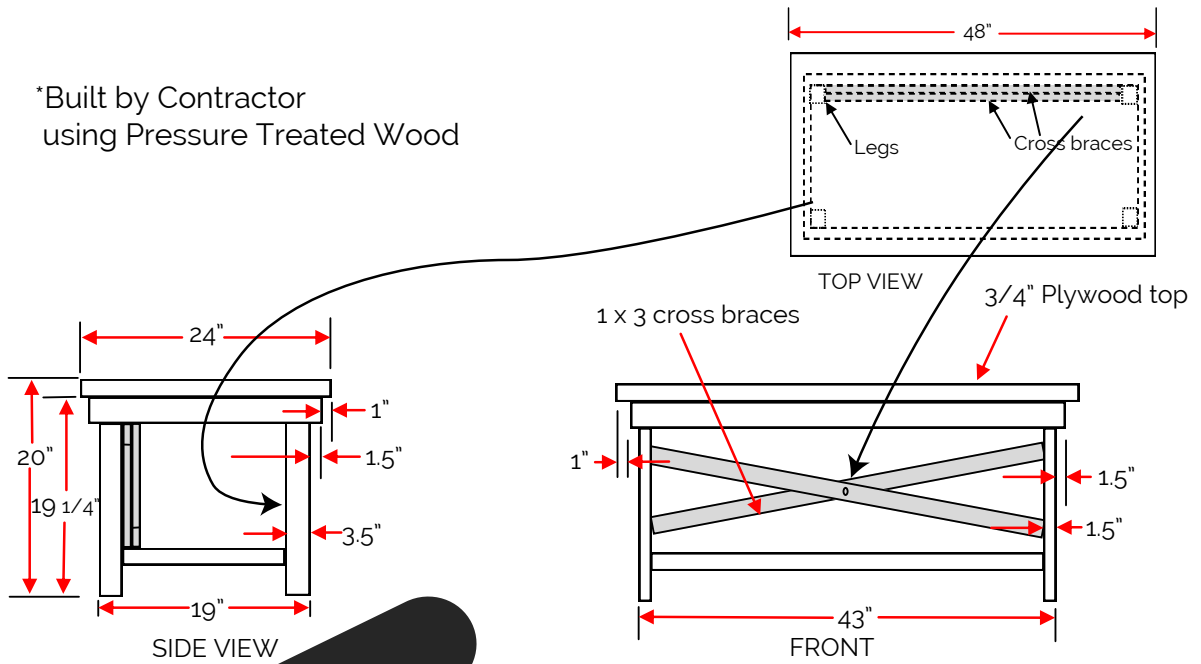

All Pressure Treated Lumber

- KEY:
- = Plywood Table top
 - = 2x4's
 - = 1 x 3 boards
 - = 2 x 6 Hook Assembly
 - Assmbl' 1x3's
 - Assmbl' 2x4's
 - Assmbl' top

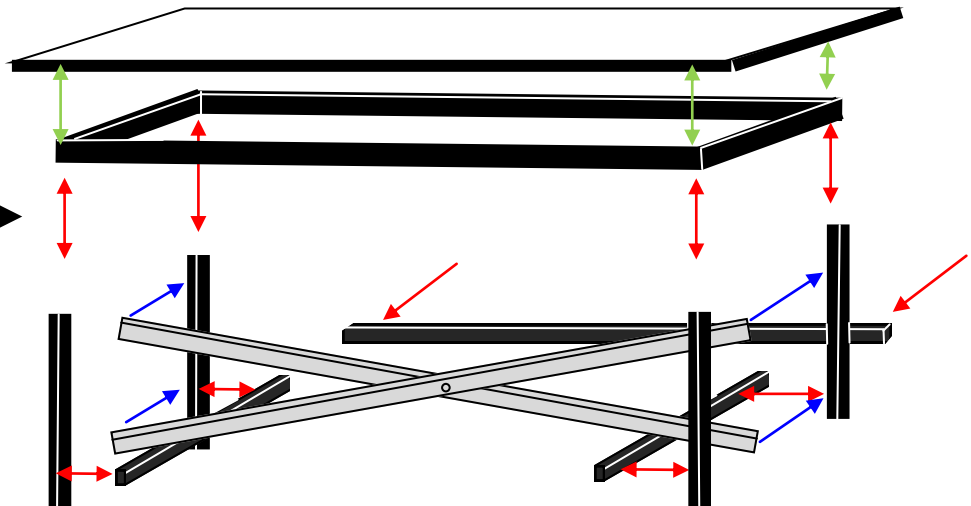

SECTION TWO:

All Tasks in this section should be
completed by:

The Handyman

Handyman - Retail Wall 3



1) Paint Instructions

- Above mural- Note that any wall or space that is over 9ft (above the mural height) is painted California Wine
- Edges- all edges trimmed in California Wine
- Mural walls and front desk- do not need to be painted, but they do need to have a basic coat of primer.

2) Mural Pre Installation Cleaning Instructions

Before you begin:

- We recommend 2 people to install your wall mural.
- If the surface has been freshly painted, please wait at least 2 weeks for the paint to fully cure.
- Do NOT use water to clean your wall before application.
- Only apply on a flat, smooth and clean surface. Do not apply on cinder blocks, brick walls and other textured surfaces.

What you might need:

- A trimming tool (Xacto Knife).
- A rubber or soft squeegee.
- A short ladder or step stool.
- A dry cloth.
- A measuring tape.

Handyman - Retail Wall 3

Mural Installation Instructions



STEP 1: PREP YOUR WALL Proper preparation of your wall is critical! Repair any visible defects, smooth out bumps and patch holes to ensure your wall is smooth and flat. If possible, remove all picture hooks, light fixtures and switch plates. Wash of any dirt, hair, dust or residue from old wallpaper with a dry cloth or a duster. Do NOT use water! A perfectly clean wall will help the adhesive backing to keep its stickiness if repositioning is required.



STEP 2: GETTING READY Open the sturdy Eazywallz packaging tube. Inside you will find your wall mural. Look for the panel number on the back of each one. Panel#1 is the first panel on the left. Unroll all panels and lay them flat on the floor, the printed side facing the ceiling. You may notice creases and/or bubbles as you unroll the panels. No worries, this is normal. The creases will disappear once the mural is flattened on the wall.



STEP 3: PEEL YOUR EAZYWALLZ Peel off the liner a few inches only across the top of the first panel. Do NOT peel off the entire liner all at once.



STEP 4: STICK IT! (PART 1) Remember that the success of the installation will depend on properly placing the first panel. Stick the top left corner of the panel to the top left corner of your wall. This is the easiest place to start. Using a smoothing tool or squeegee, smooth the top of the panel onto the wall. Do NOT use pressure to avoid any scratches.



STEP 4: STICK IT! (PART 2) Peel off the rest of the panel by gradually and evenly pulling down the liner, a few inches at a time. We recommend having the other person hold the bottom of the panel as you work your way down. Once the first panel is applied, and if necessary, remove any bubbles by gently pushing them outward with the squeegee.



STEP 5: ADDITIONAL PANELS Start by aligning Panel#2 to Panel#1. Simply stick the panel against the edge of the first one, by matching the pattern of the mural. Follow STEP 4 above to apply the rest of Panel#2. Repeat the same process to apply all additional panels.



STEP 6: TRIM OVERAGE Once all panels have been applied, SLOWLY trim all the overage with an utility knife with a sharp blade (ie: Xacto knife). Follow the edges of your wall or ceiling to do so. You can also use a ruler to cut through a straight line. If needed, repeat this process to cut around outlets, fuse boxes, windows, doors, etc.



STEP 7: REMOVAL PROCESS Slowly and gently pull the panels from the wall. Use your hand to gradually hold back the wall mural during this process. To avoid any damage to your wall while removing, keep the wall mural as flat and parallel to the wall as possible. We highly recommend to keep the backing liner (wax paper), so you can re-apply the wall mural to it. It will protect the adhesive from losing its stickiness and allow you to re-use your wall mural.

Handyman - Mural Installation Tips

- Note the numbers in "cor" on the back sides of the murals.
- Lay them all out in order order on a clean surface and match up the lines and patterns BEFORE taking any sticky backing off.
- After you are sure the the pattern is correct, lay your first piece from top to bottom, about 6 inch sections at a time.
- Use something flat, dull, and straight (squeegee, dust pan, plastic paddle.. ect) to get the bubbles out of each section as you adhear it to the surface.

Handyman - Work Area: Grooming Station

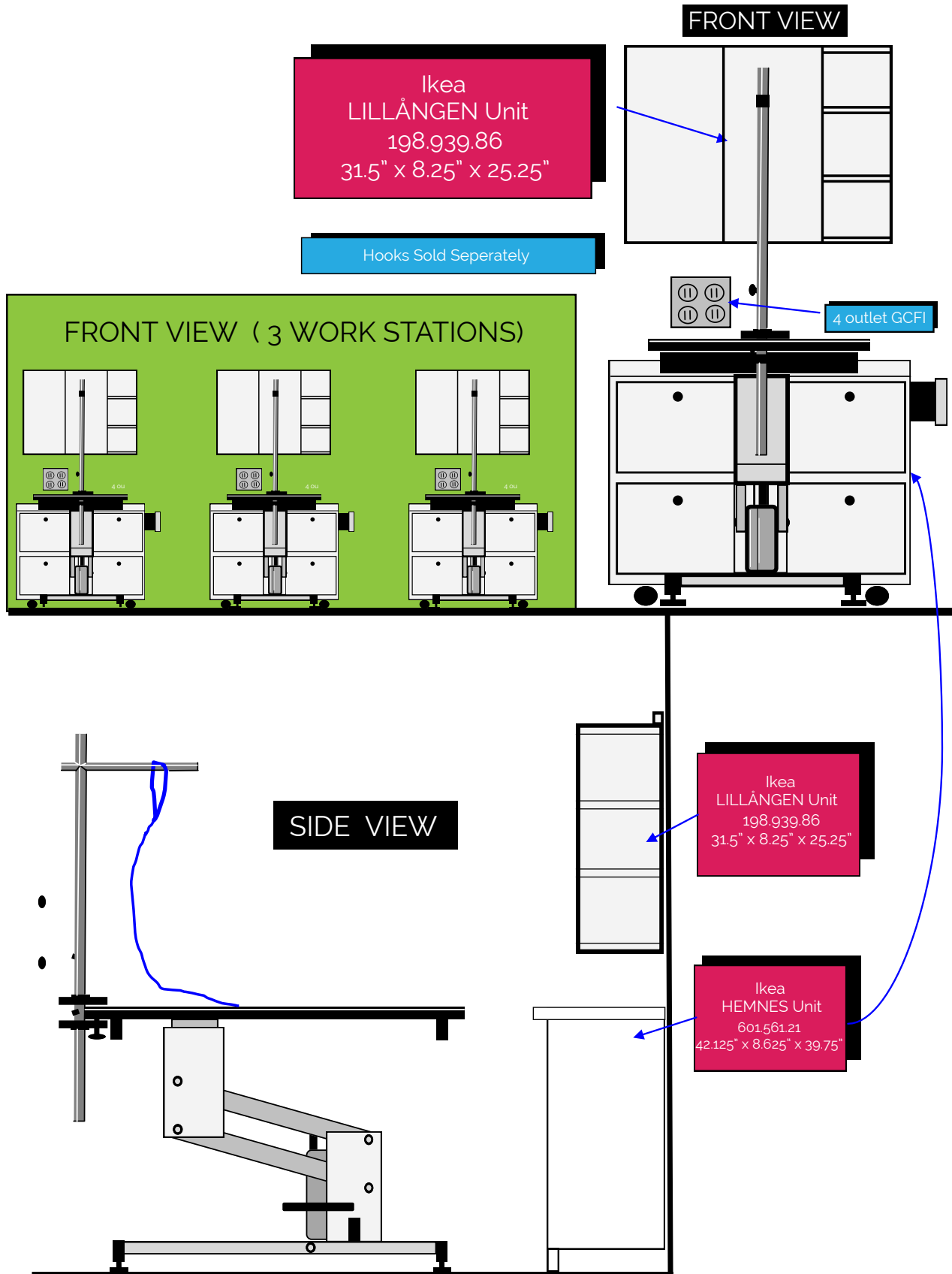

Handyman - Ikea Assembly Tips

- Only open **ONE BOX AT A TIME**. Complete one shelf at a time before moving on.
- Wait to put in any shelves until inventory comes and placement of product is made so you can fit the shelves according to the product on them.
- Do not mount the shelves to the walls.
- Save all extra parts in a bag.

Handyman - ULine 2x8 Food Planogram

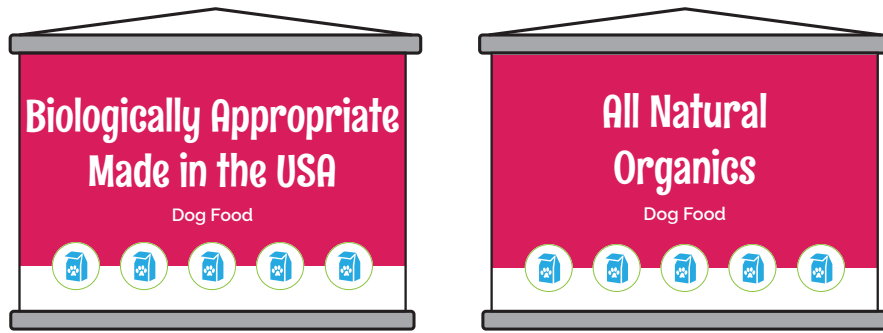

96"

Peg #1

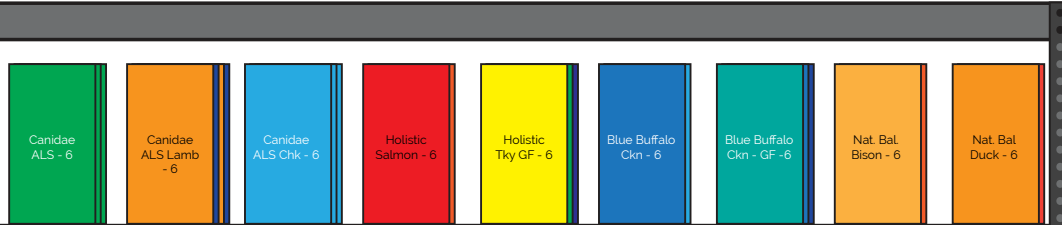

Peg #14

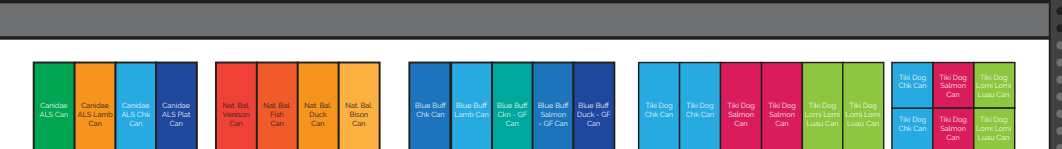

Peg #23

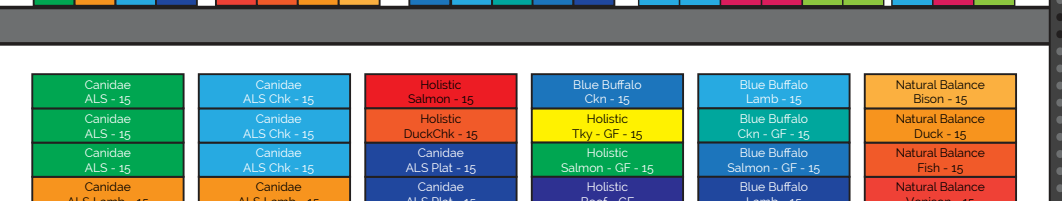

Peg #35

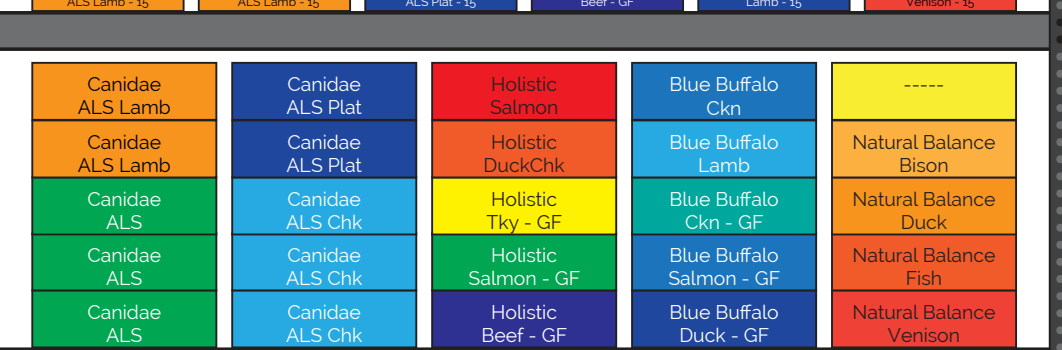

Peg #55

16"

10"

14.5"

26"

84"

Second Shelf - Top View

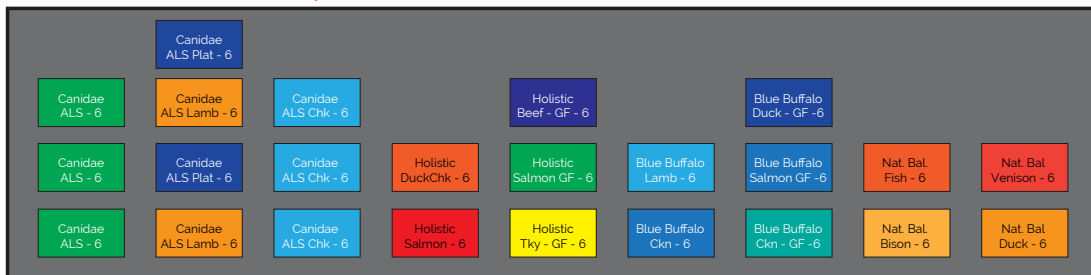

Handyman - ULine 2x6 Food Planogram

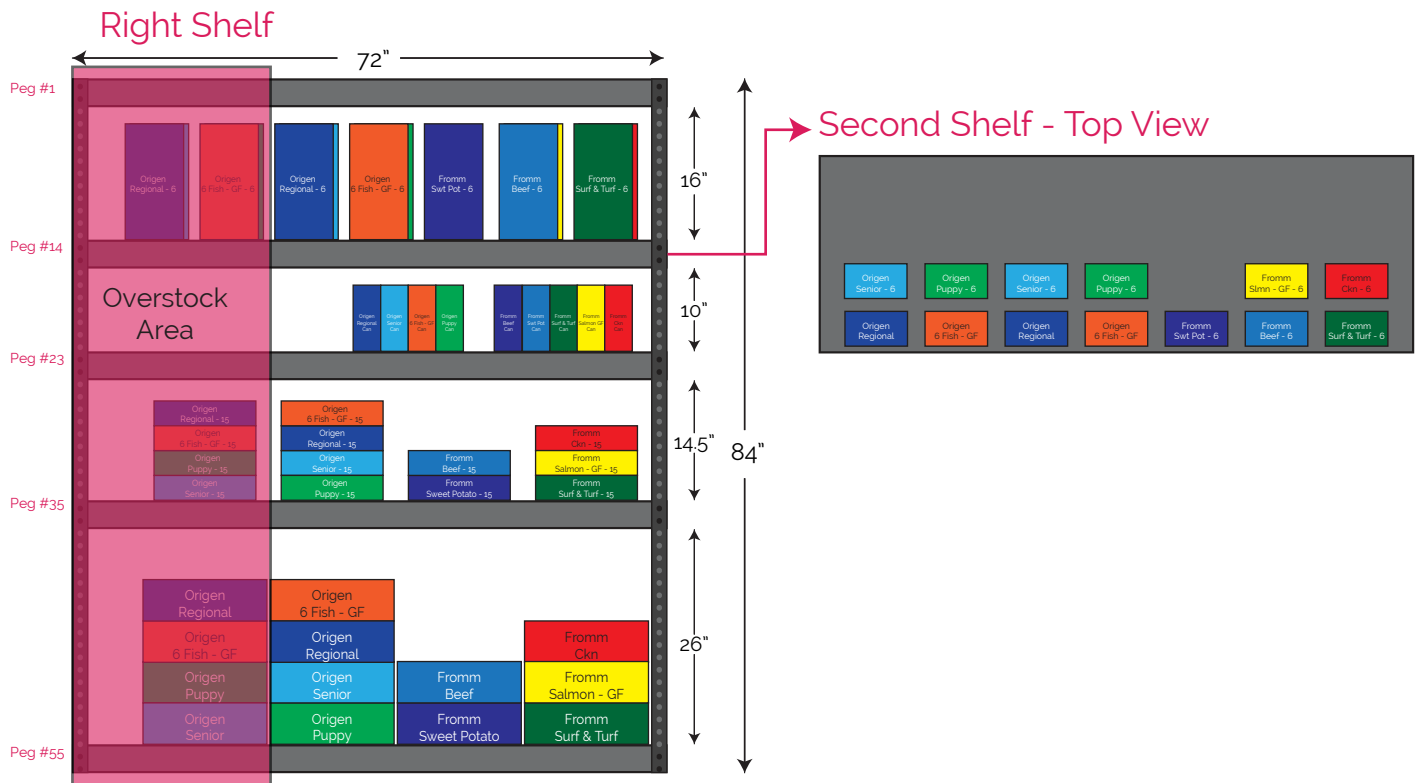
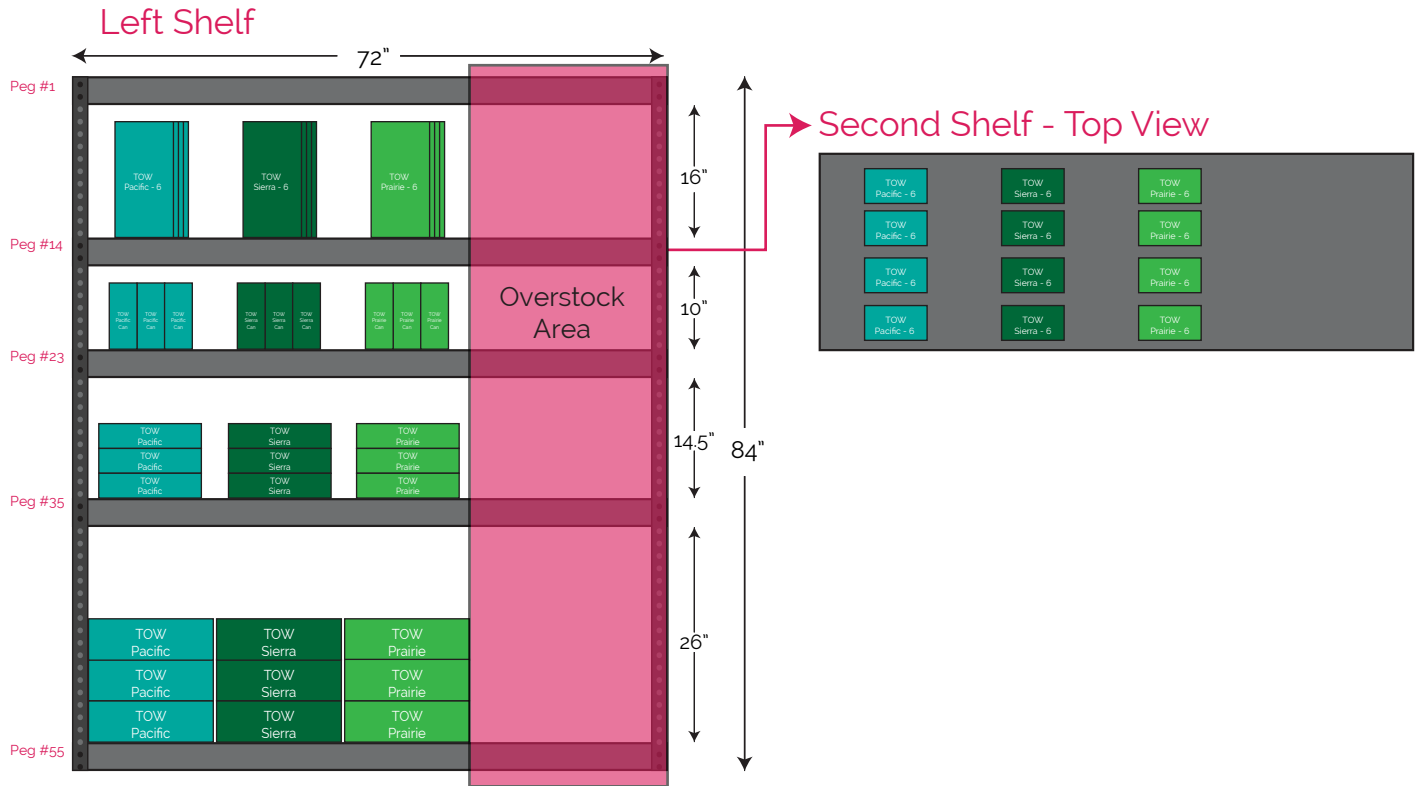

Handyman - Equipment Pictures - Racks



[Enlarge & Video](#)

WIDE SPAN STORAGE RACKS - PARTICLE BOARD

Store and unload heavy, bulky items with convenient four-way access to shelves.

- Quick, easy assembly. Shelves snap into place and adjust at 1 1/2" increments.
- 3 shelves hold up to 1,800 lbs. each.
- 96" boards ship in two pieces.
- Smooth, solid 5/8" board eliminates item fall-through.
- Includes shelf supports and particle boards.
- [Wire Decking Shelves and Posts](#) available.



FREE [H-2215 Rubber Mallet](#) UPON REQUEST WITH ANY \$200+ WIDE SPAN ORDER. Use sale code **SP230** at checkout.

Handyman - Initial Inventory Setup Tips

- Take the USB hookup for the front desk scanners and plug one of the scanners into a laptop on the computer cart. You can now have the computer follow you around the store as you enter in products instead of running back and forth to the desk to enter the products.
- List all the different brands you are entering into the system on a separate sheet of scrap paper as you enter inventory. That way you can simply search the already entered products by brand and print all of those labels at once after an entire section is completed.



Handyman - Tall Bookcase Assembly

Tall Shelves LED Set UP

Put your pins for the shelves into the sides from the top: 12 down, then 14 down from there, and down another 12.

1) Hole placement for LED wires according to Shelf placement



2) Example of how the wires come out and the shelf sits



3) Shelves and Wires in place with double sided sticky for LED lights



4) Wires neatly gathered and tied (back of bookcase)

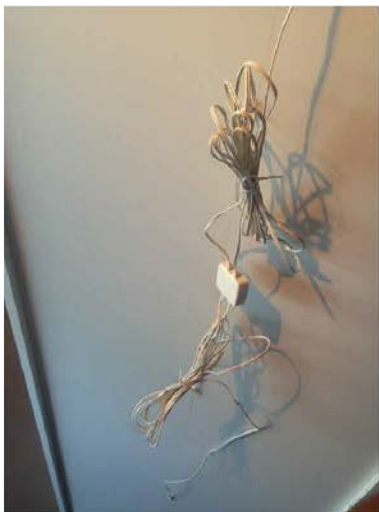

5) Finished



Handyman - Spa Sink and Cabinet

Spa Setup:

- Hang the mirror where the top of the mirror lines up with the top of the tall ikea shelves.
- Do not build the 3 units together. Build them individually and place upside down so you can screw the metal riser to the bottom.
- Face both of the small units forward
- Do not put the hinges or door on the larger unit.

1a and 1b) Screw the door on the back end via the mounting brackets and separate wood screws.

1a)



1b)



2) Do not use the predrilled holes to secure together. Line up the front edges and secure together with a separate half inch wood screw or drywall screw.



3) Put the covers on the mounting brackets to make a flush finish



4) Finished



Handyman - Collar Ladder Assembly

- Clip the collars with the design on the front and the clip in the back with the tag facing forward as well.
- Face the same designs in a vertical manner. so all of the same designs match down the ladder.
- Hang the overstock on the back side of the ladder and move them forward as needed.
- Situate both of the same sized collars next to each other on the same rung.



Handyman - Slatwall Panels

Slatwall Aluminum Inserts - 8'



Double Slatwall weight capacity.

- Easy installation. Simply slide into channel from side of panel.
- Use with 4 x 8' [Uline Slatwall Panels](#).

Slatwall Panel - 4 x 8', White Melamine



Turn your walls into merchandising display space.

- Durable, no-maintenance finish.
- Strong 4 x 8' panels of 3/4" Anchor Core board.
- 15 channels per board, spaced 3" apart on center.
- Anchor Core board is 50% stronger than standard fiberboard.
- [Slatwall Accessories](#) and [Aluminum Inserts](#) sold separately.

Special Notes:

1. Before cutting down to 4' section, 1st insert the Aluminum Inserts in all the channels.
2. Flip over the Slatwall, so that the chrome inserts are facing down, and then cut down the middle with the aluminum inserts in all the channels
3. You'll need a blade that can cut the slat wall and aluminum inserts at the same time. Most "general purpose" blades will be fine
4. Take your four foot panels and have 2 people hold them steady, so that the top of the slat wall is equal with the top of the tall shelves (approximately 72 inches off the ground), and drill at least 5 pilot holes through the slat wall panel and the wall (two holes in the top corners, two holes in the bottom corners, and one directly in the middle) so that the holes will line up perfectly when the wall is situated again.
5. Remove the panel from the wall and put your drywall anchors into to the pilot holes you just created.
6. Have your 2 assistants hold the slat wall up one more time, this time, screwing the slat wall to the anchored pilot holes.

Handyman - Slatwall Placement

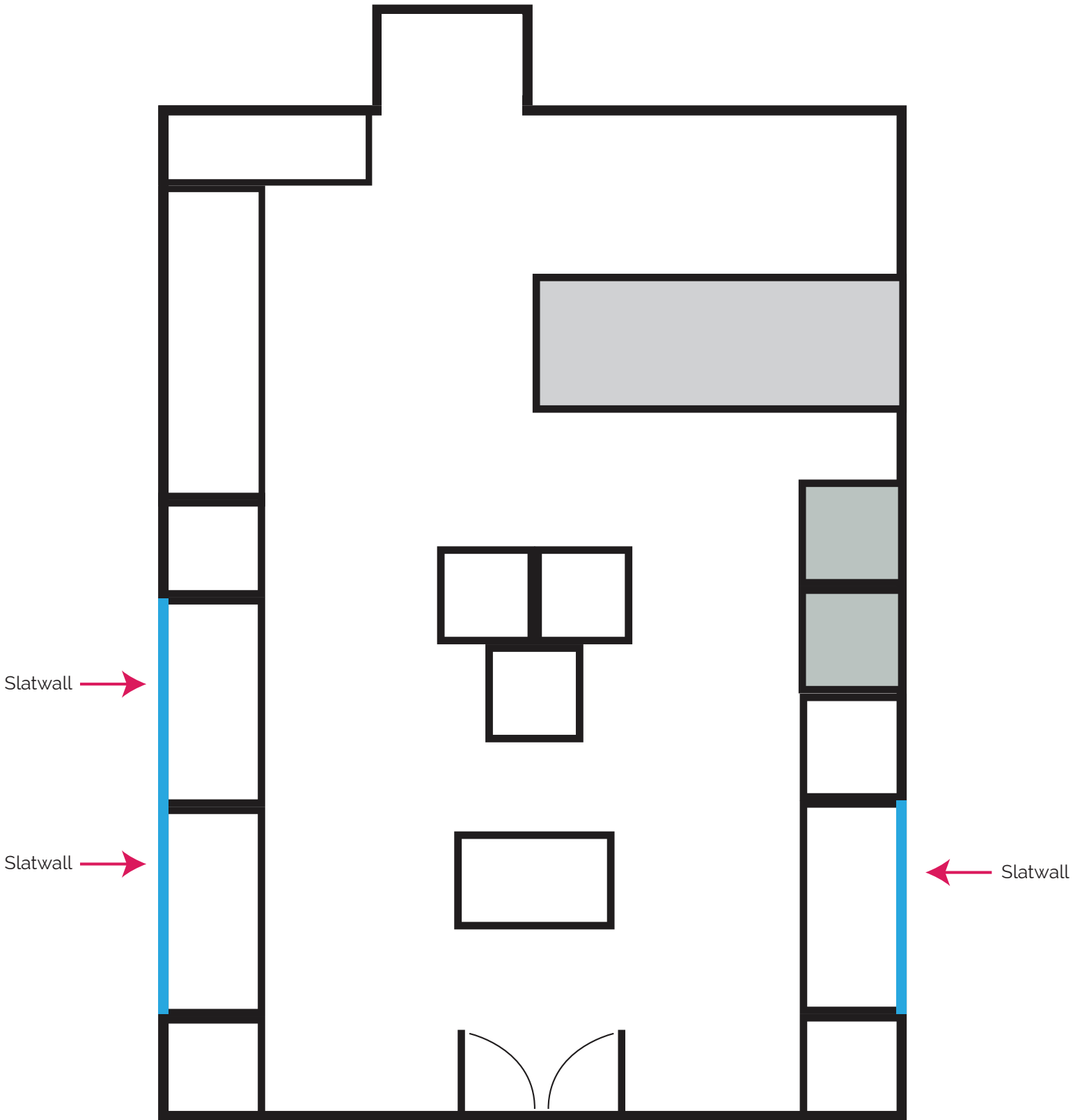

Handyman - Grooming Area: Large Work Bench

*Built by Contractor using Pressure Treated Wood

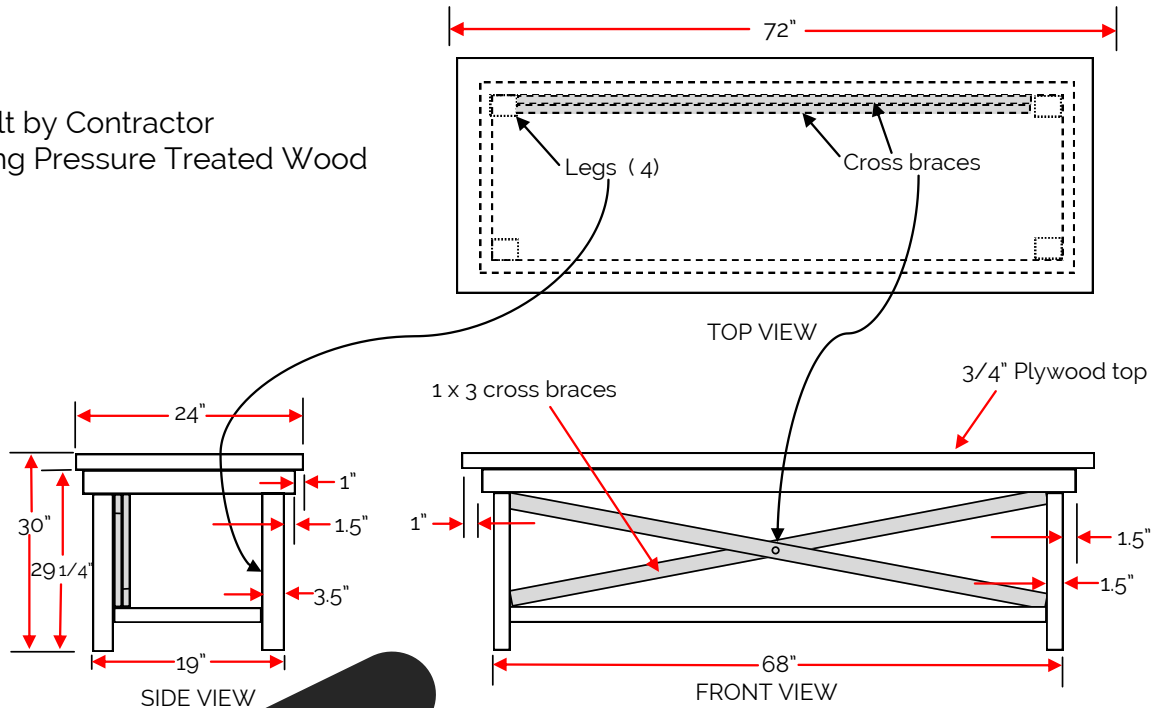

Add matting table top cover entire surface.

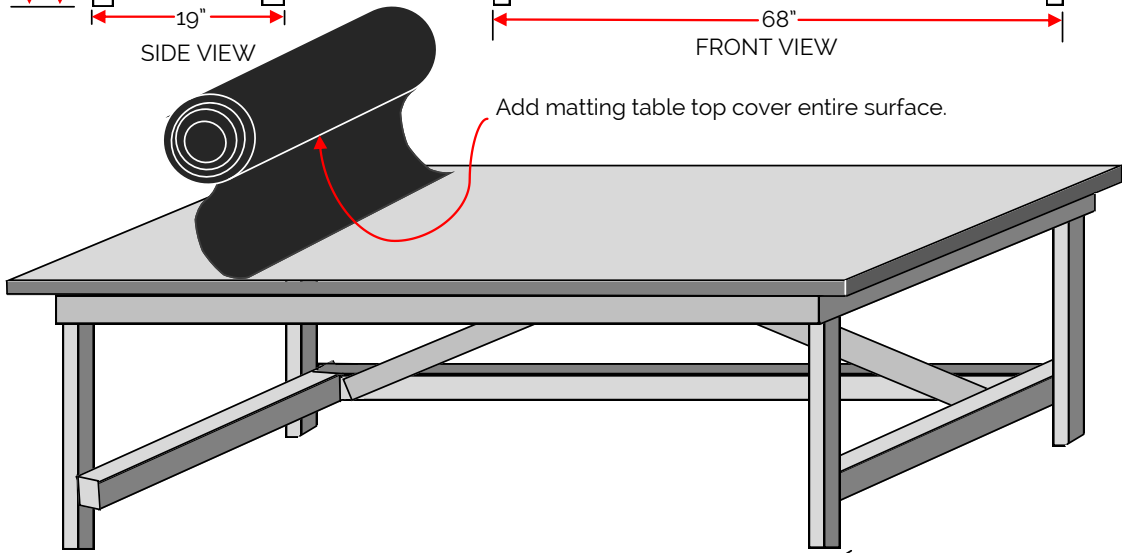

All Pressure Treated Lumber

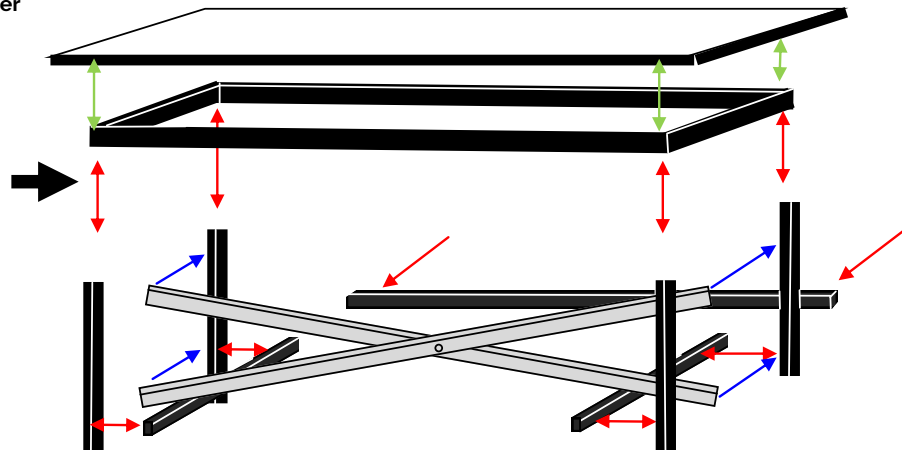
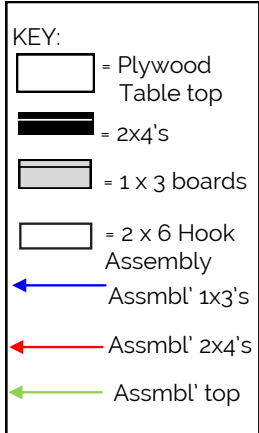

Handyman - Grooming Area: Small Work Bench

*Built by Contractor
using Pressure Treated Wood

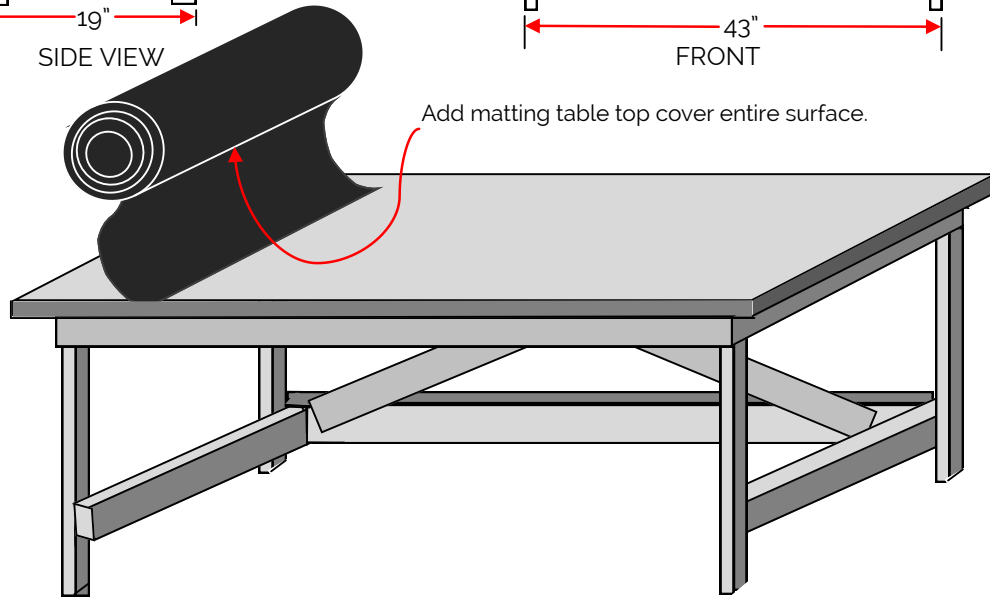
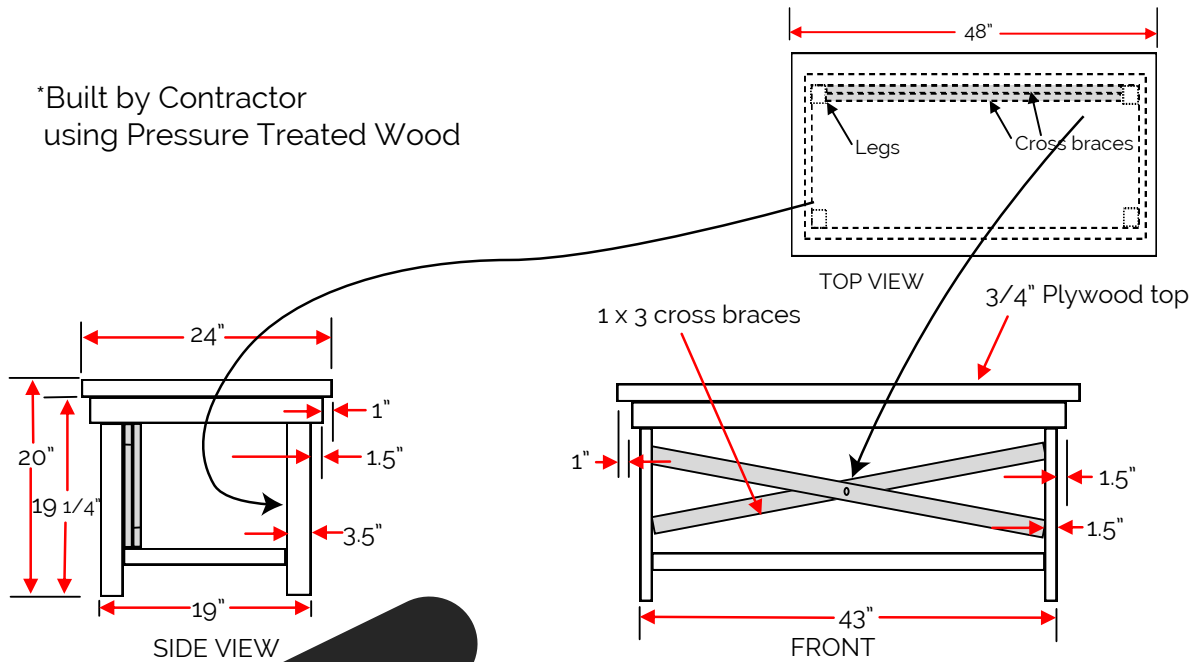

All Pressure Treated Lumber

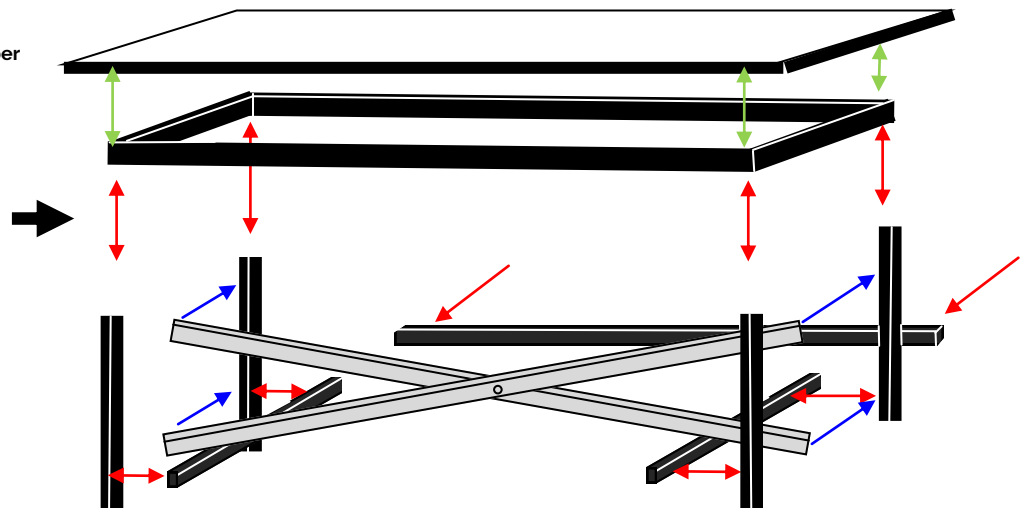
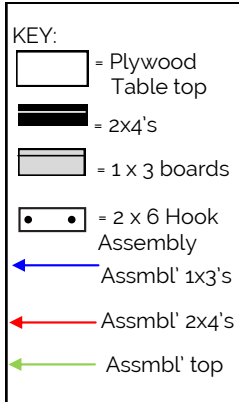

Handyman - Grooming Area: Laptop Cart Setup

Power Cable
(when necessary)

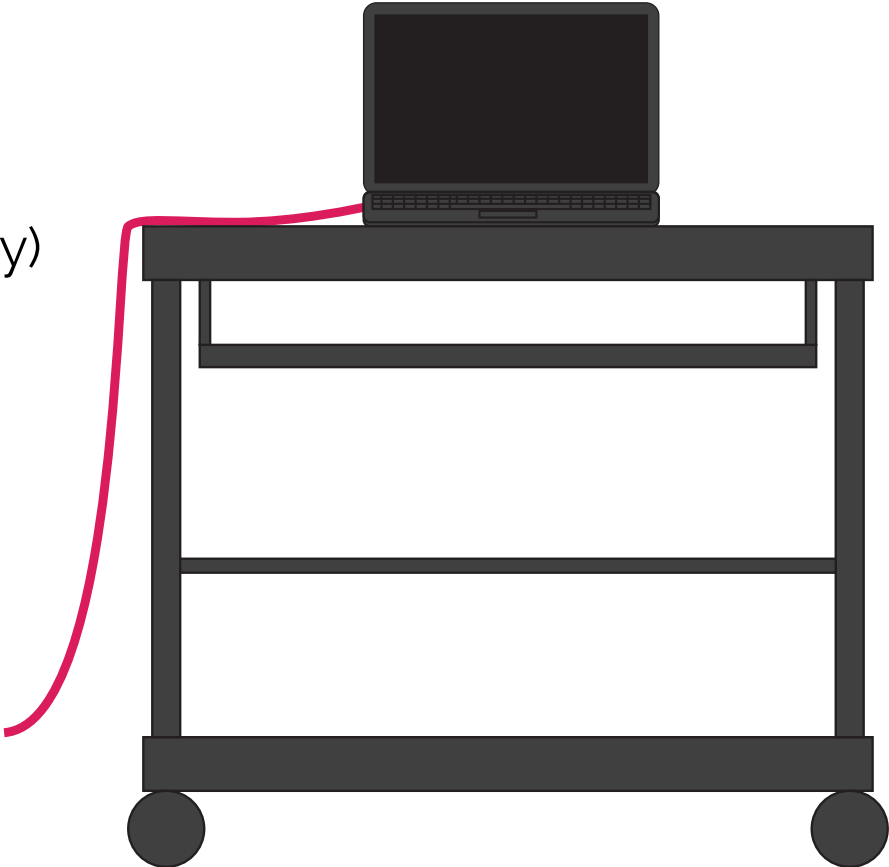

SECTION THREE:

All Tasks in this section are to be
completed by:

The Electrician

Electrician - Store Front Electrical Plan

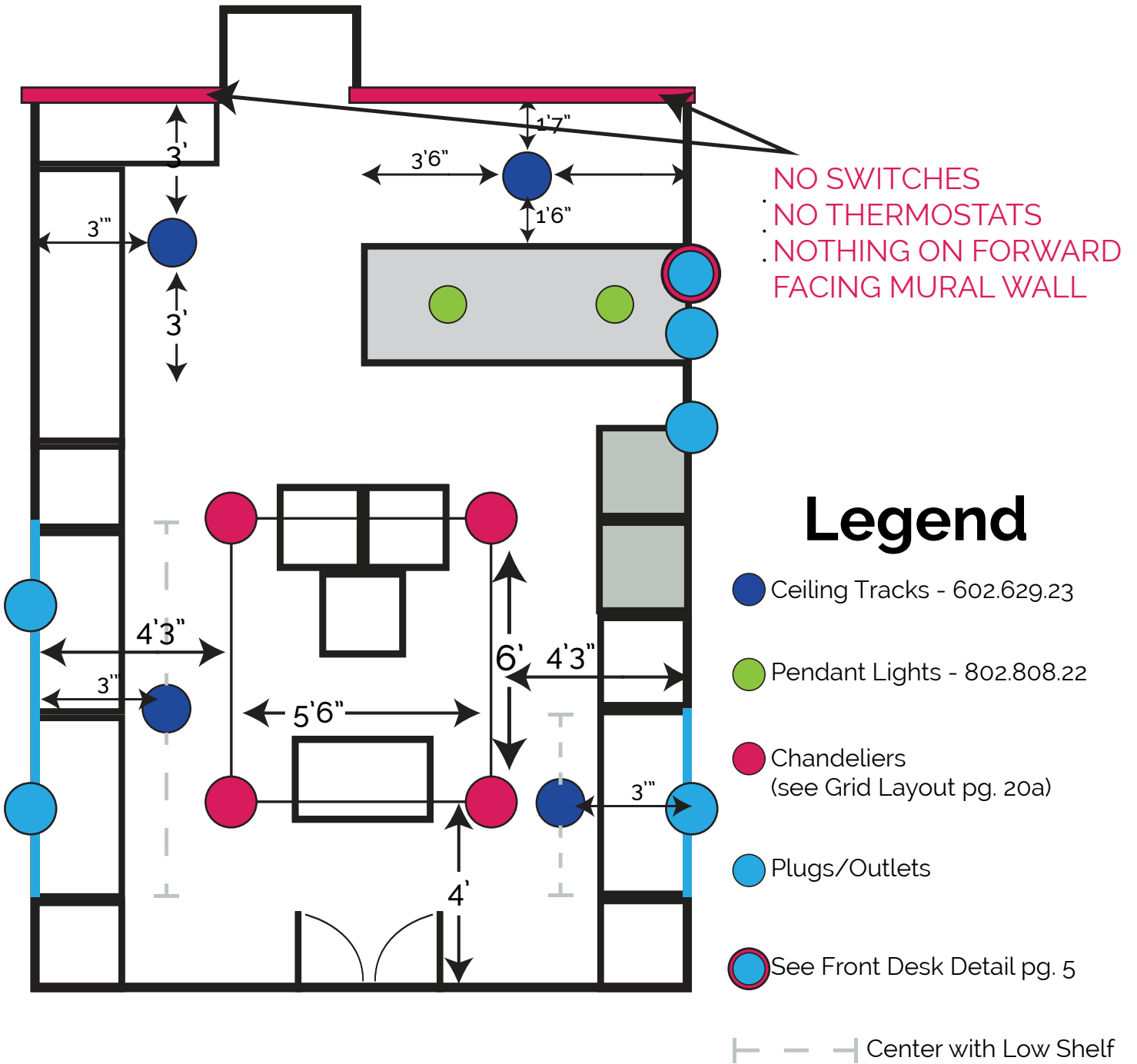

Electrician - Store Front Lights



HUSINGE
602.629.23



SVIRVEL
802.808.22

ATTENTION:

No Electrician changes to be made to back of the shop.
Retail changes only.

Electrician - Drying Table Details

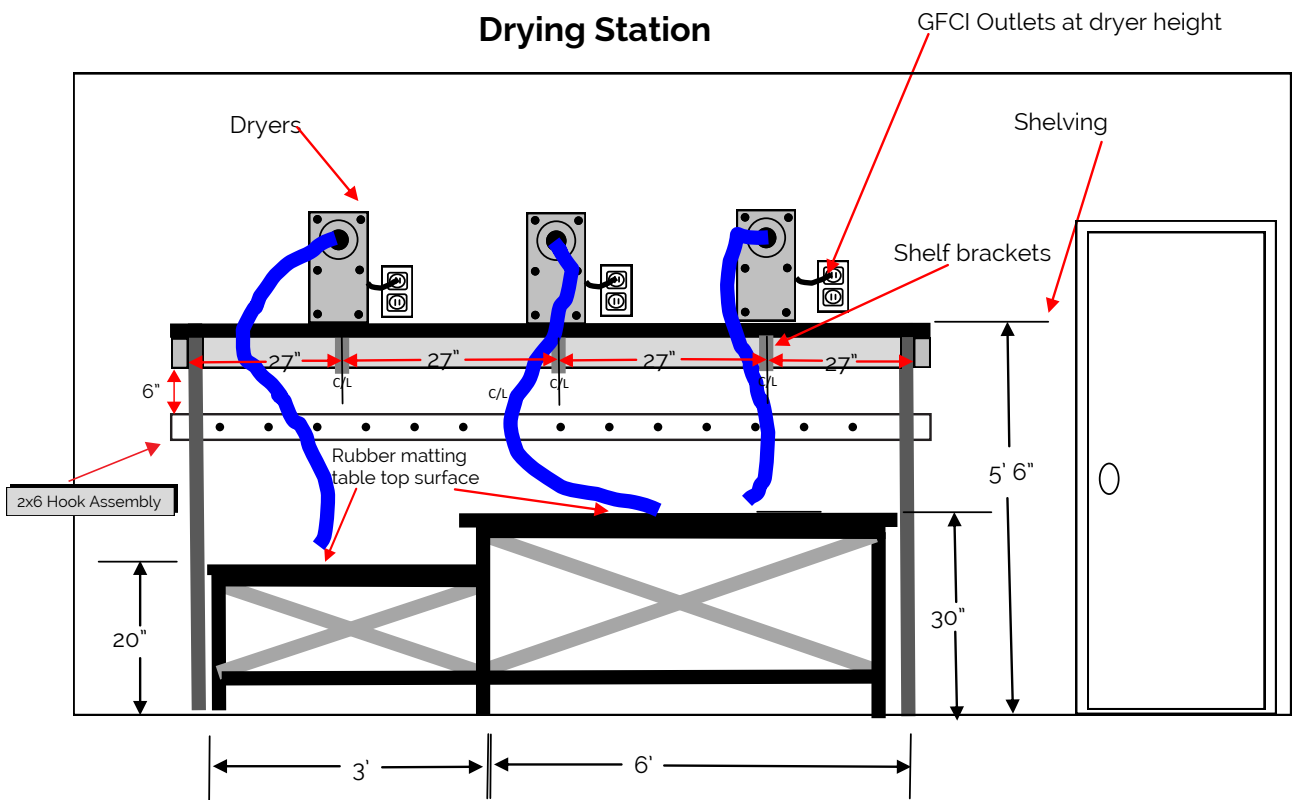



Regular Dryer **Manufactured by HURRYCANINE**

15 Amps
Heavy Duty Galvanized
Steel
192 CFM 2 Speeds

One Year Warranty
14" L x 15 1/4" T x 8" W
1 1/2" W x 8 1/2' L Hose
24 Lbs.

** 220 volt available for installation of your country's plug **

Electrician - Ceiling Grid Detail

Side Profile

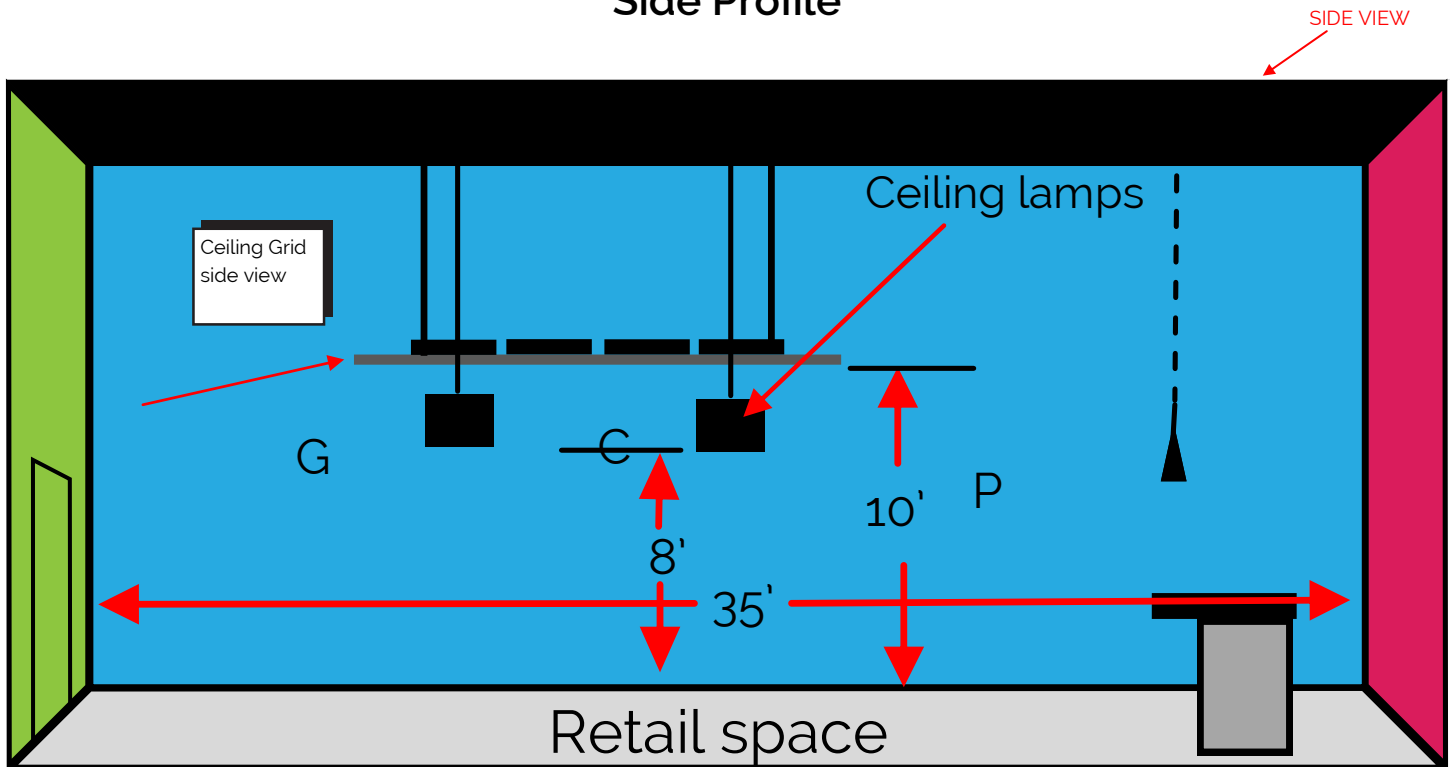

For placement on ceiling, see attached CAD Drawings

Electrician - Ceiling Grid Layout

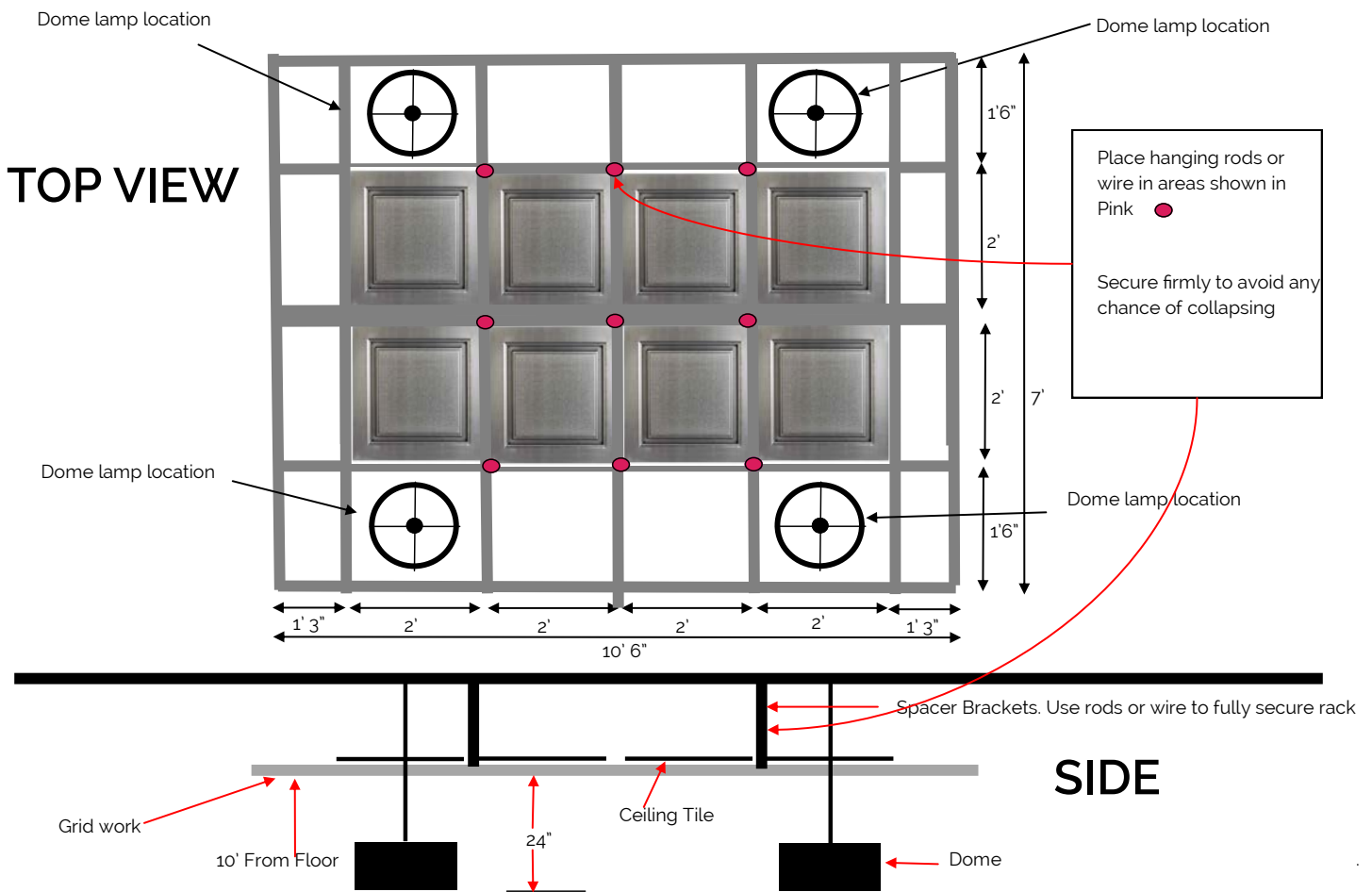

- Lay out all pieces on the ground in proper placement before pulling the joints together.
- Plan out your ties to the roof as well and your center line.
- Make sure to get even lengths for the wire holding the sections up. Secure at all joints.
- Hang your first middle square assembly and secure to ceiling.
- Build the rest of the grind in the air and have on person handing parts while the other secures them together and ties them to the ceiling.
- This project is not difficult but it is time consuming. make sure your GC plans ahead for the extra labor as well as time to get this centered and visually pleasing.

Electrician - Ceiling Grid Assembly Tips

- Lay out all pieces on the ground in proper placement before putting the joints together.
- Plan out your ties to the roof as well and your center line.
- Make sure to get even lengths for the wire holding the sections up. secure at all joints.
- Hang your first middle square assembly and secure to ceiling.
- Build the rest of the grid in the air and have one person handing parts while the other secures them together and ties them to the ceiling.

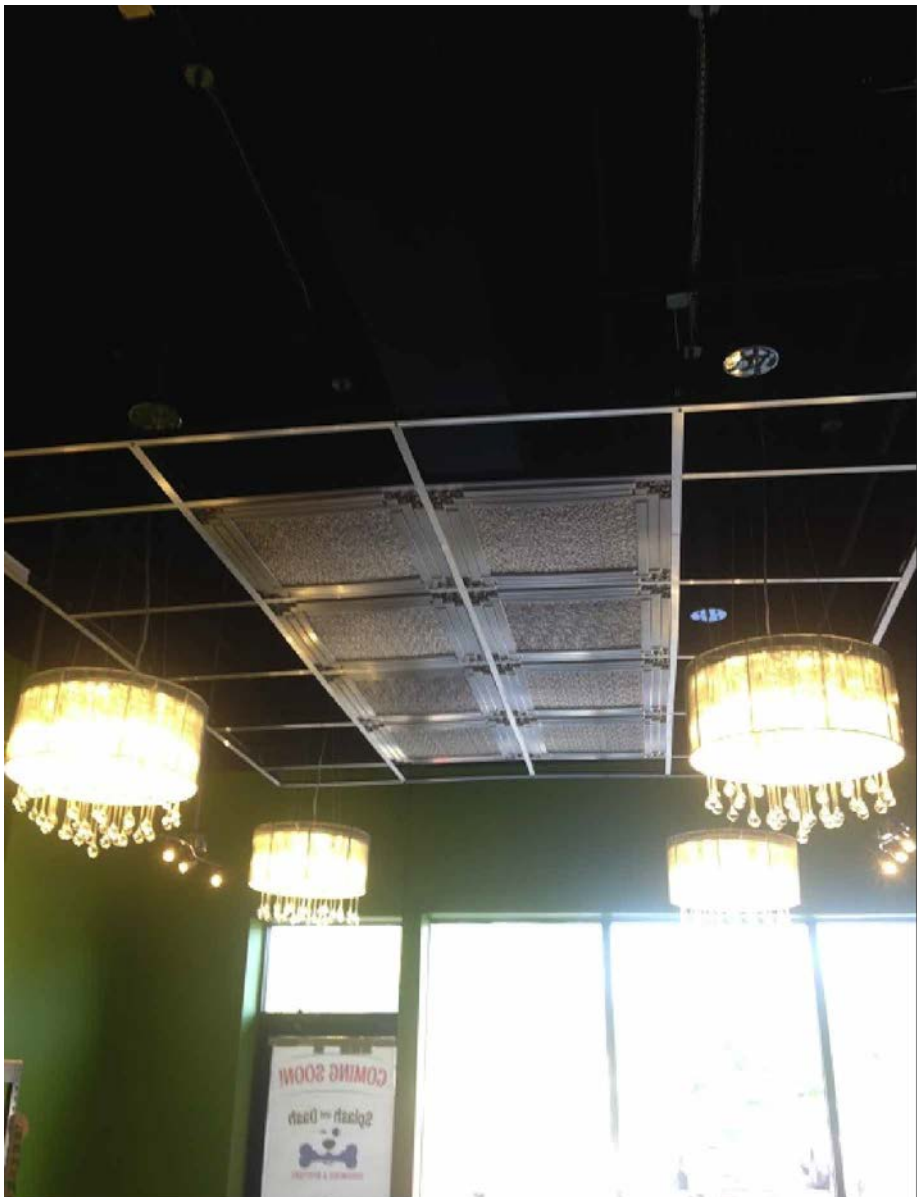

SECTION FOUR:

All Tasks in this section are to be
completed by:

The Plumber

ATTENTION:

No Plumber changes to be made to back of the shop.

Plumber - Work Tub Stations

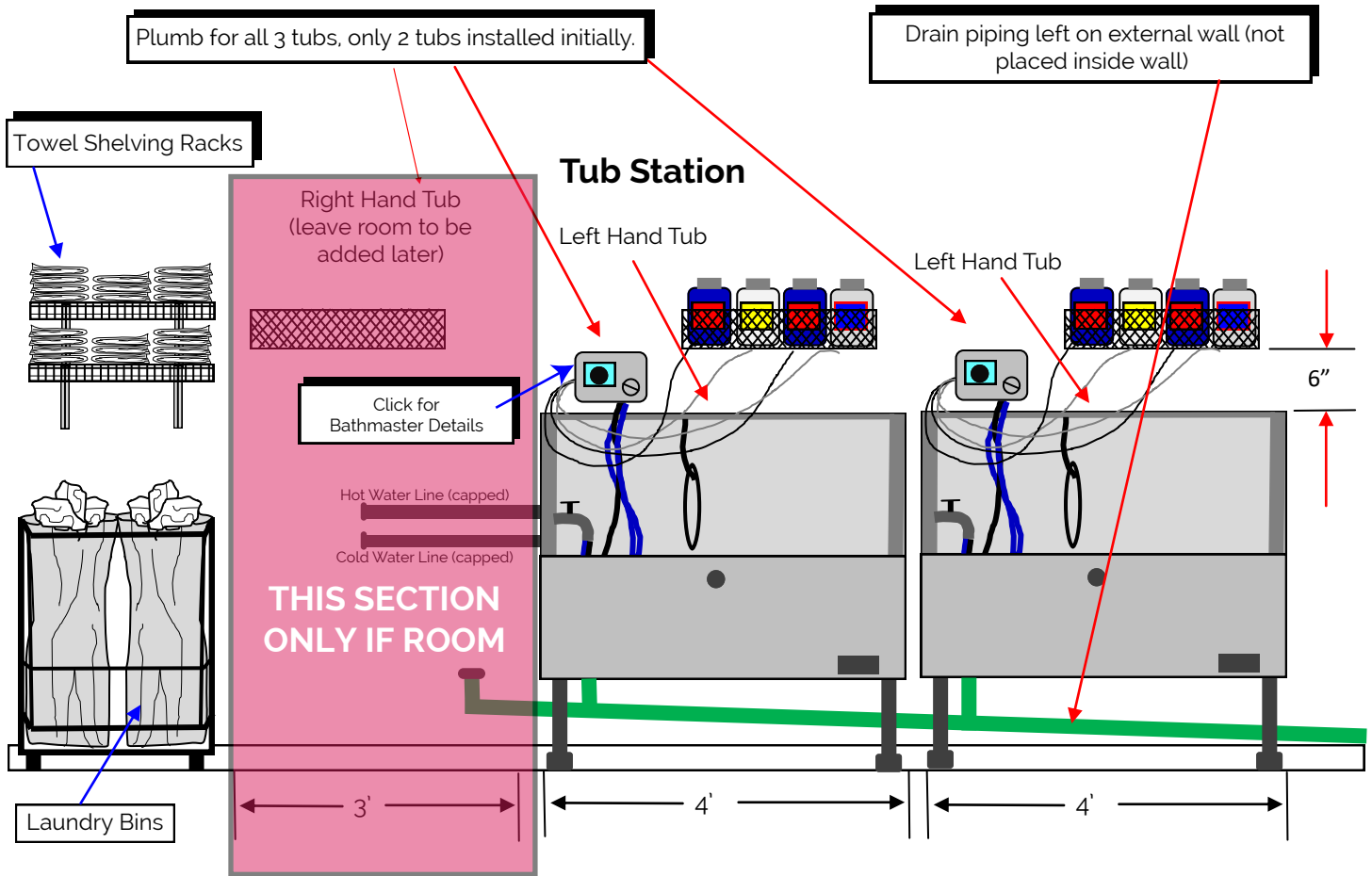
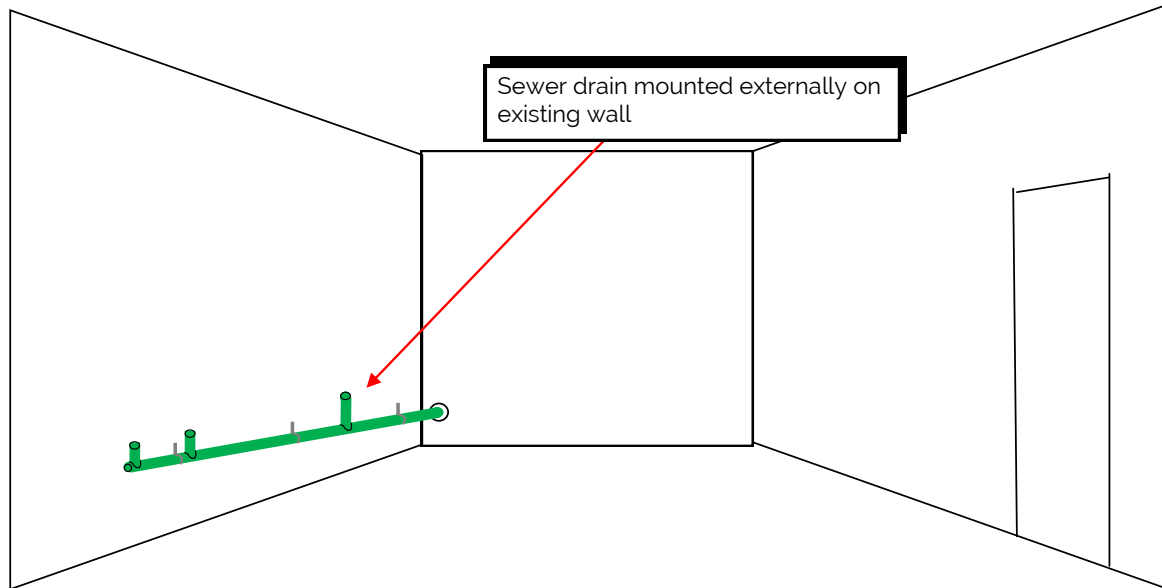

Dura Dog Premier Stationary Stainless Steel Tub (GTU50S)

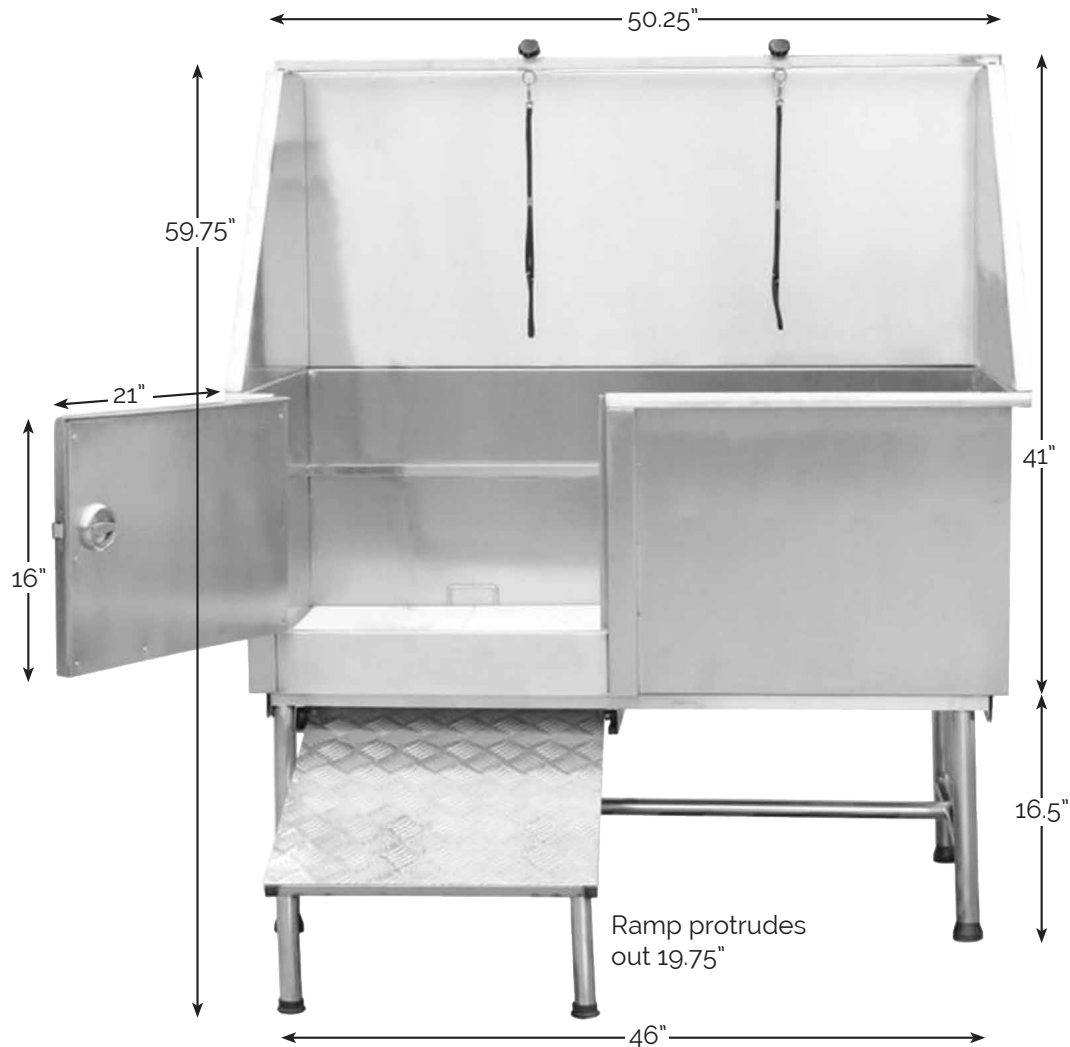

Plumbing Specs

The drain hole is 3.5" in diameter and is slightly off-centered from front to back in the tub, which puts the center of the hole at 12.5" inches from the front and 12.25" from the back and 14.25" from the side of the tub on center. The three faucet holes are 4" on center. The holes are 1 1/16" in diameter and up 22" from the bottom of the tub itself or approximately 38.5" from the floor. From the backsplash, the center of the first hole is 6.5", the middle hole is 10.5" and the last hole is 14.5".

Additional Specs

The distance between the faucet holes is 4" and the distance from the welded corner to the last faucet hole is 7.5".

Plumber - Bathing Station Assembly

- Assemble the tubs **BEFORE MOUNTING** the Bathmaster and shampoo racks on the wall as to know where the comfortable height above the tub will be.
- Situate so that the shampoo rack is slightly higher than the bathmaster to help the siphon, but still make it within reach to change out shampoos easily.
- Install Bathmaster all the way to the right of the tubs and only about an inch or two above the back wall of the tub, let the rinse hose lay over the right side into the tub.



SECTION FIVE:

All Tasks in this section are to be
completed by:

The Painter

Painter - Wall Paint Colors

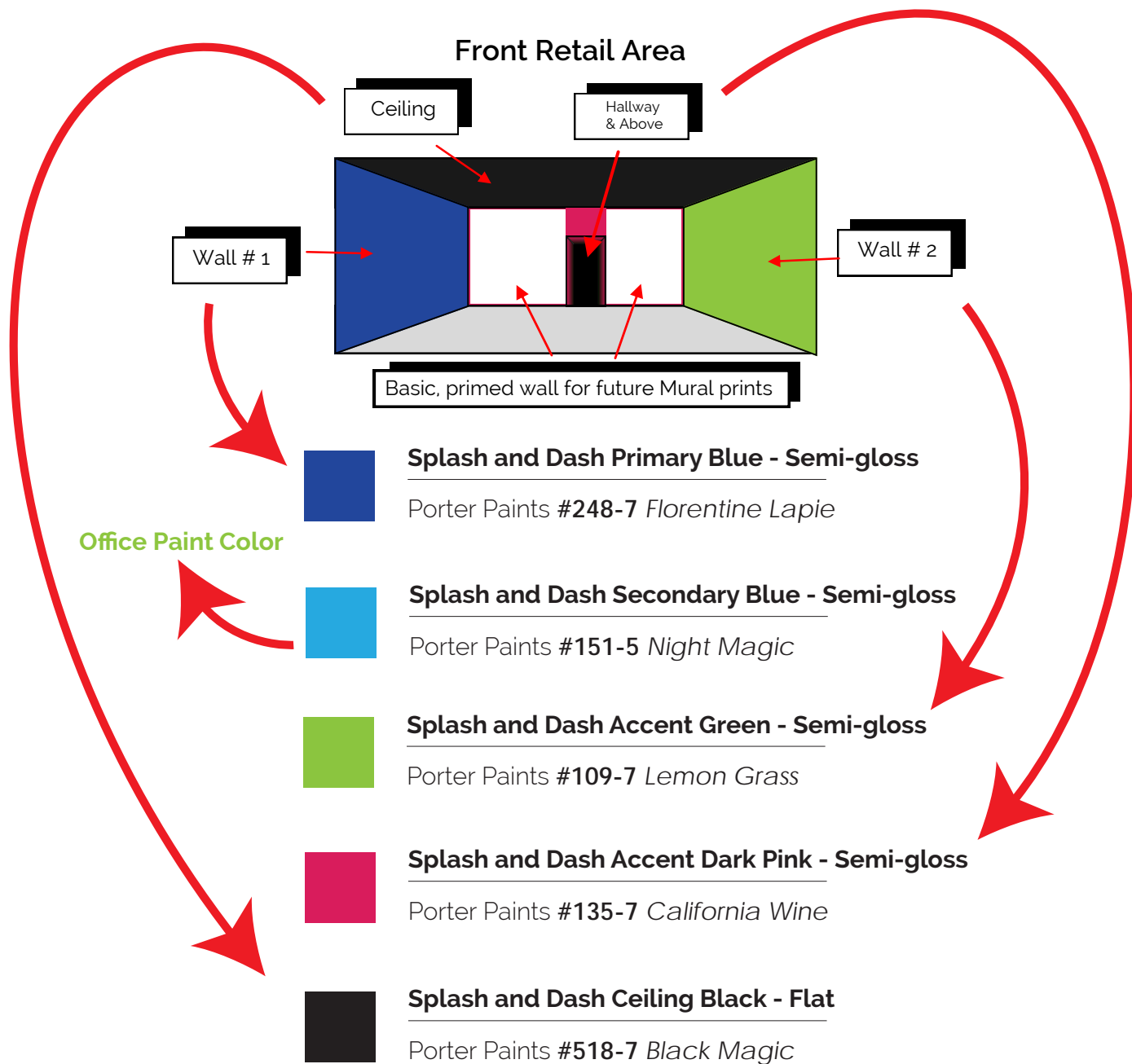

Notes

- Wall 1 - color is ran all the way back in working area
- Wall 2 - color is ran all the way back in working area
- Back wall/Mural Wall - edges of wall will be trimmed in 4" trimmed in California Wine
- Hallway - In California Wine
- Ceiling - sprayed in Black Magic
- Front Interior Wall of Store - Lemon Grass
- Floor - Gray epoxy paint, No flakes added to floor
- Back Area - interior walls are Semi gloss white.
- Base boards - Standard Black vinyl baseboards

SECTION SIX:

All Tasks in this section are to be
completed by:

The Shop Owner

Owner - Store Front Ikea Furniture Placement

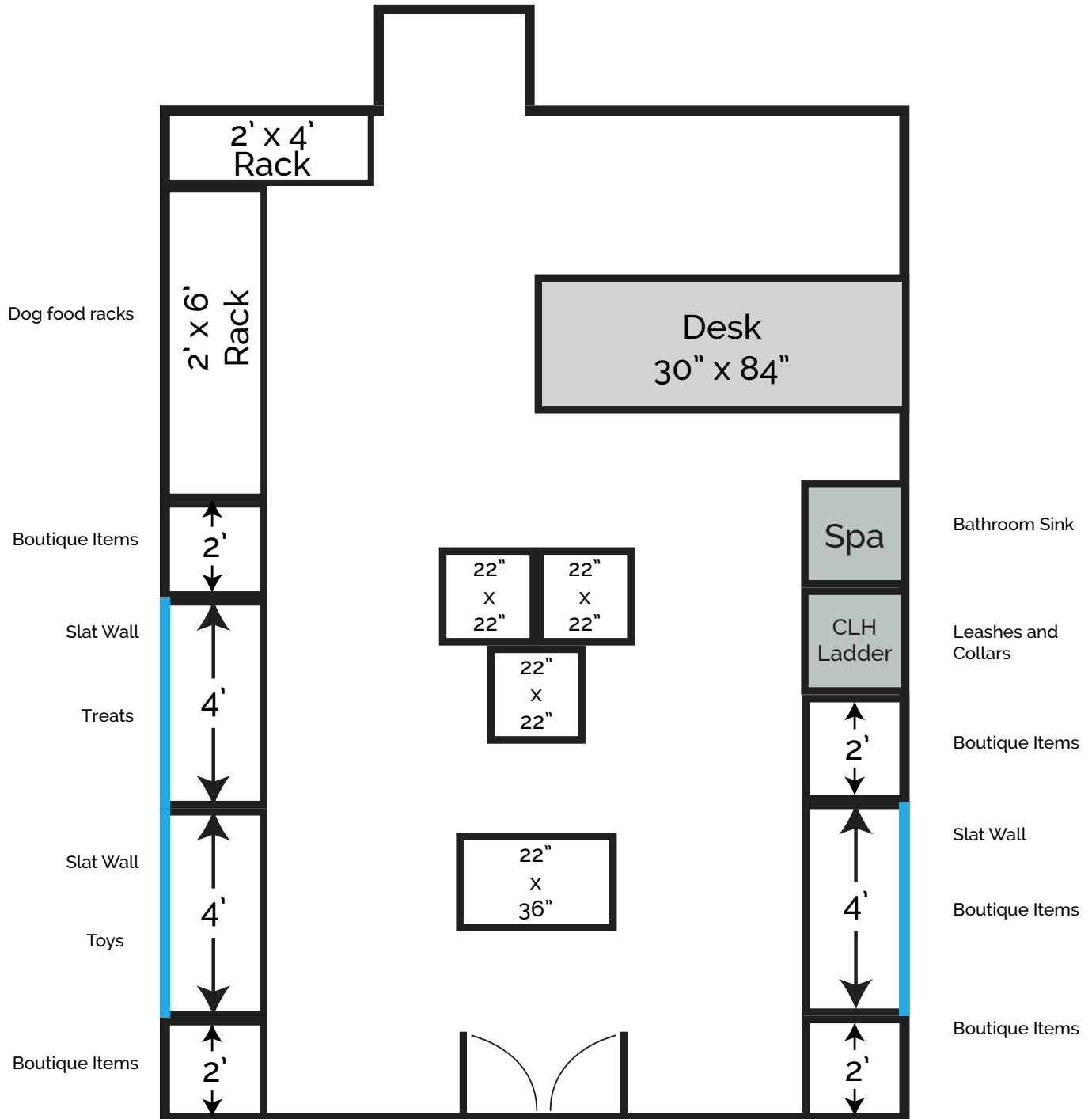

Owner - Store Front Signage Placement

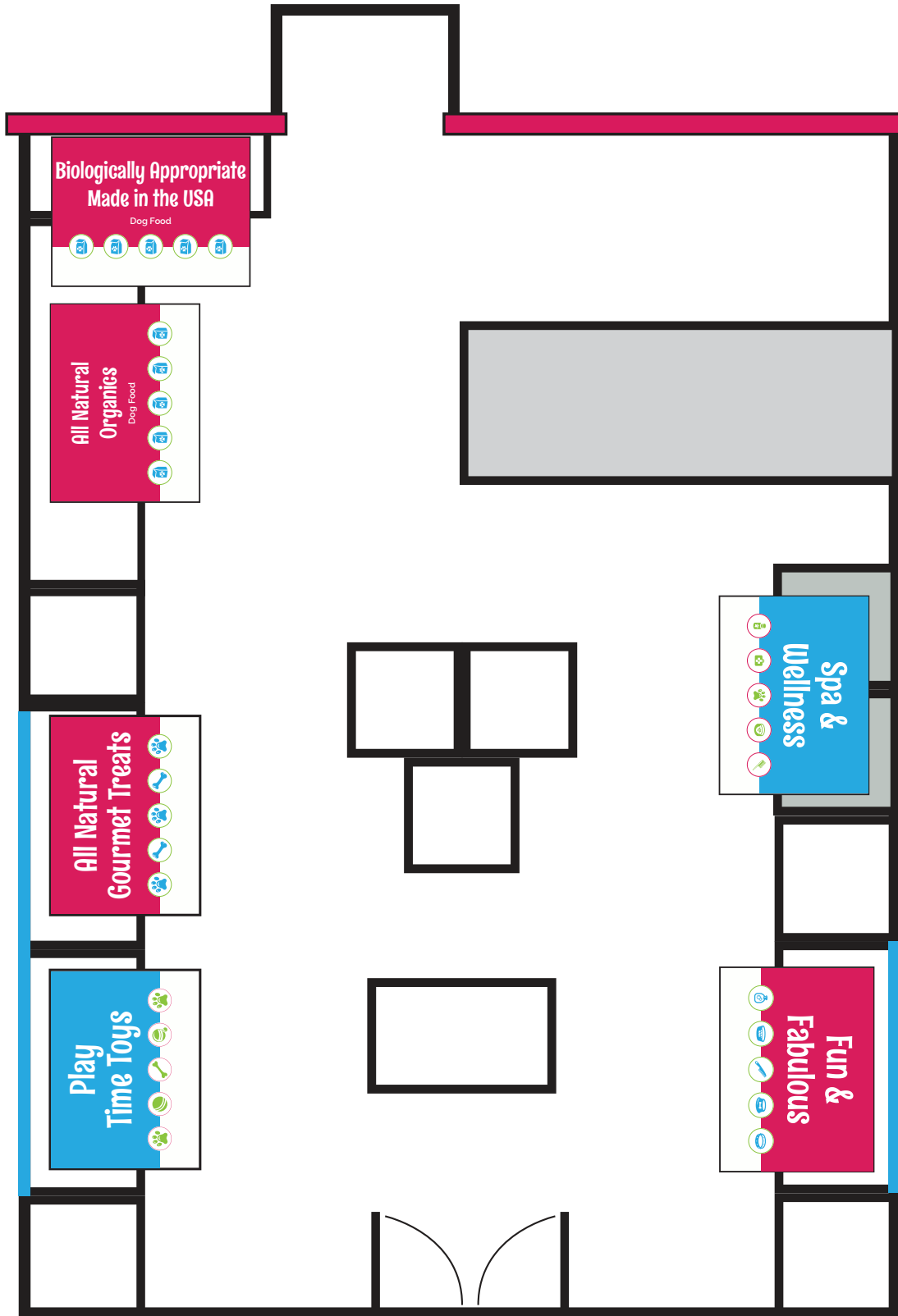

ATTENTION:

No Owner changes to
be made to back of the shop.
Retail changes only.

Owner - Splash and Dash Requirements

- 1) Dog food racks always opposite wall of front desk.
- 2) Office always opposite wall of front desk.
- 3) Use **TRIANGLE** pattern from desk, dog food, and office.
- 4) Always have a figure eight design from the front door to the desk area.
- 5) Area closest to desk against wall should never have a tall cabinet, always open, for a poster on wall or uses low cabinet if any.
- 6) ● Keep open space and use wall spacing for posters.
- 7) Identify single and 5 light system with colors.
- 8) Doors are on auto hinges.

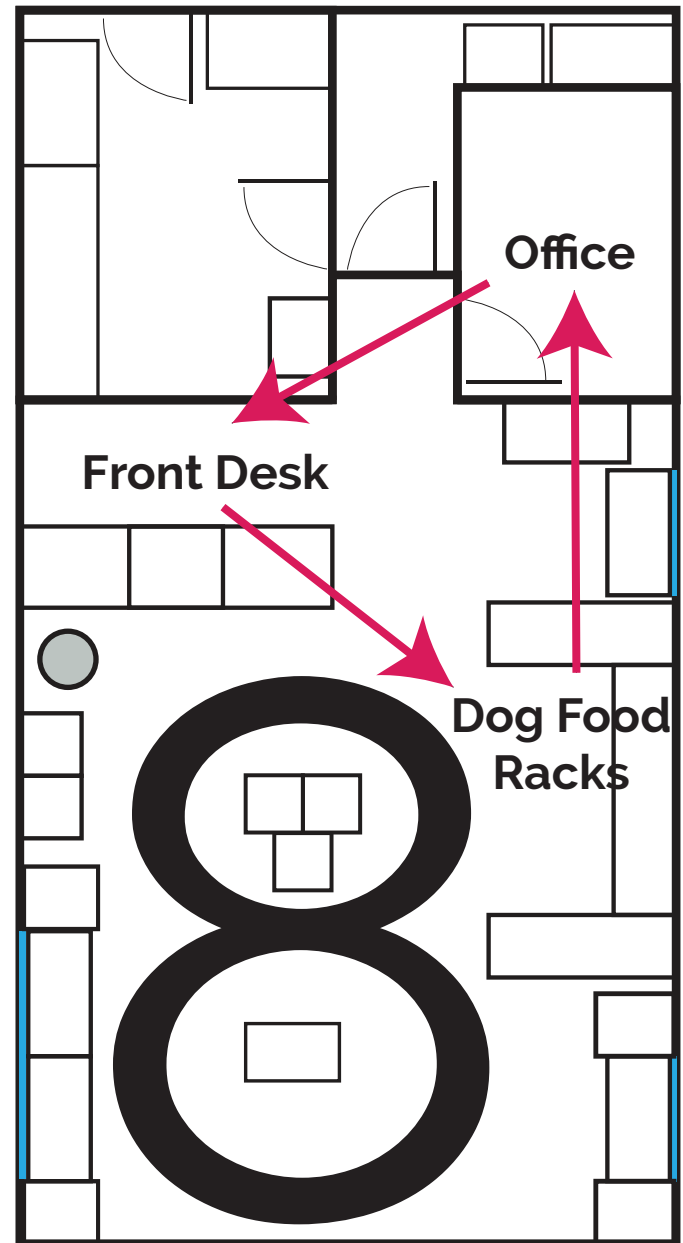

- = Electrical outlet location for Rail Light
- = Electrical outlet location for Pendant Light
- = Electrical outlet location for Chandelier Light

Owner - Retail Desk PC Setup

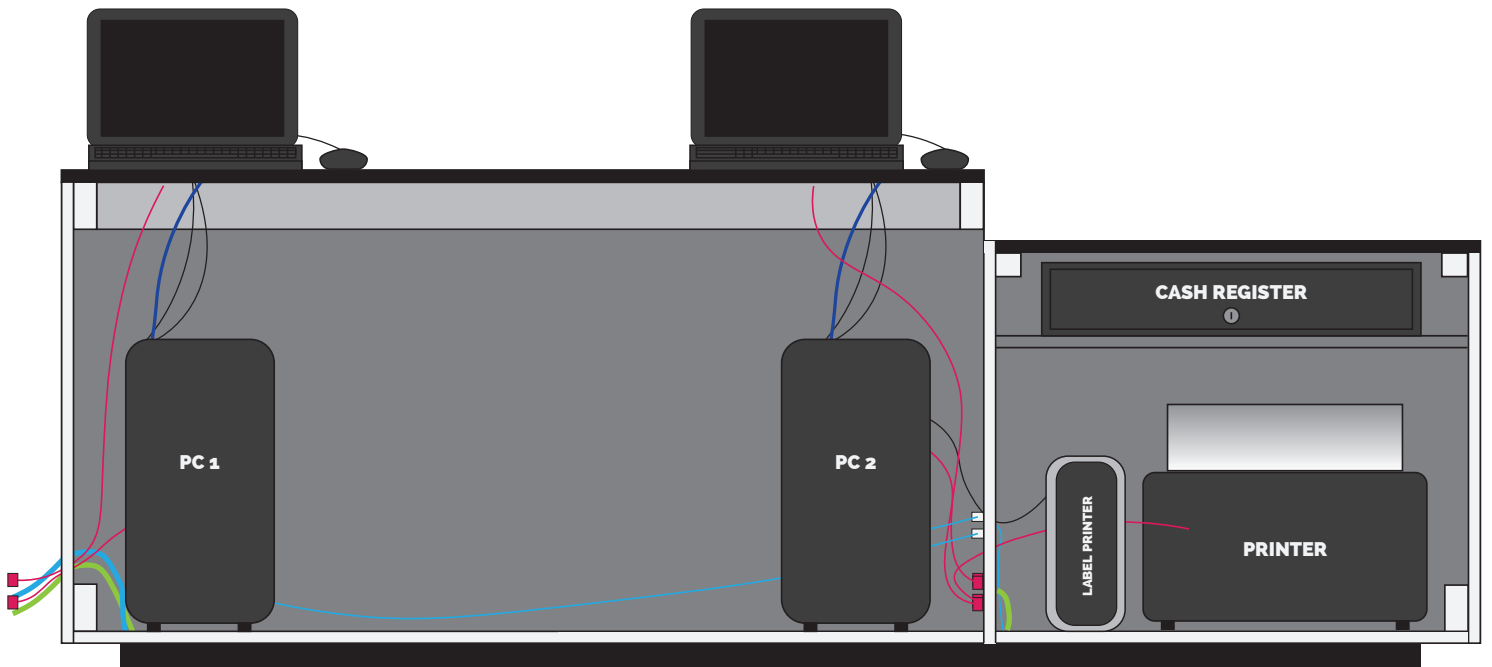

Cable Key

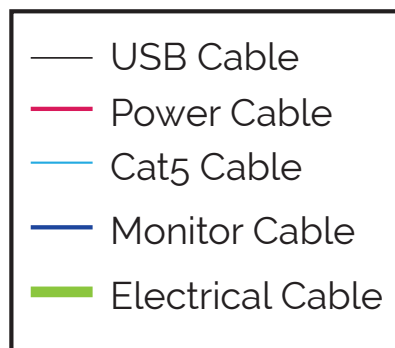

Disclaimer

All plans and illustrations contained in this publication are the exclusive property of SD Franchise LLC, dba Splash and Dash Groomerie & Boutique and reproduction in whole or in part is strictly prohibited by law.

All information and construction plans contained within this document are provided AS IS. SD Franchise LLC, disclaims all other warranties, express or implied, including merchantability or fitness of purpose. Construction plans must be submitted to a local architect for approval. SD Franchise LLC is not liable for incidental, special, consequential, or indirect damages of any kind, including, but not limited to, loss of anticipated profits, business opportunity or other economic loss arising out of the use of services or any construction plans received from SD Franchise LLC, even if SD Franchise LLC has been advised of the possibility of such damage.

It is the franchisee's responsibility to ensure the accuracy, compliance with applicable statute(s) or regulation(s), and fitness of purpose of any plans or construction information received from SD Franchise LLC prior to the use thereof.

Information on Building Codes:

SD Franchise LLC, does not assume any knowledge of local, state or federal building codes. All plans MUST reviewed by a local professional architect or engineer before the start of construction or such services that are best handled by those familiar with your local building codes.

Plan Usage

1. All plans are protected by Federal Copyright Laws. Any use of the information contained herein beyond the one-time use authorized by SD Franchise LLC. of prints, or any duplication, publication, sale or distribution of any part of these plans without the prior written consent of SD Franchise LLC Designer represents a violation of Federal Laws subject to the prescribed penalties.

2. Any use of the plans, or modifications of the plans, by Franchisee, builders or others is done at their own risk. Franchisee should have the plans reviewed by a local professional architect or engineer before the start of construction. The information contained within the construction documents is intended to depict design and basic construction detailing. It is the builder's responsibility to provide standard construction details and practices which will result in a structurally sound and weatherproof finished product.

Plan Content

These Plans provide ideas and concepts and are not intended to be complete in all respects and details. Variations in standard sizes of window and door brands and types and use of different materials and thicknesses can change details. Varying local codes, ordinances, regulations, foundation requirements, and the layout of electrical, mechanical, and plumbing systems can also change details.

Responsibility of Builder/Contractor hired by Franchisee

1. It is the responsibility of the builder to assure that all work is in accordance with the latest edition of all applicable Nation, State, and Local Building Codes. It is the builder's responsibility to ensure that all work is conducted in accordance with the latest edition of all applicable Construction Standards.

2. It is the responsibility of the builder to ensure that all manufactured articles, material, and equipment are applied, installed, connected, erected, used, cleaned, adjusted, operated and conditioned as directed by the manufacturers. Builder shall follow all instruction to sustain and preserve all expressed or implied warranties and guarantees.

3. It is the responsibility of the builder to assure that all materials, equipment and components are new and of good quality.

4. It is the responsibility of the builder to check all dimension and details for overall accuracy appropriate to the local conditions and the final selection of materials such as masonry, floor joists, lumber, structural members, construction panels, roofing, etc., all of which can create variations in dimension and details. For example, if standard lumber joists are used in place of engineered floor joists, the floor-to-floor dimension would vary from the Plans and require revised stair dimension and framing.

Splash and Dash



GROOMERIE & BOUTIQUE

www.SplashAndDashForDogs.com